

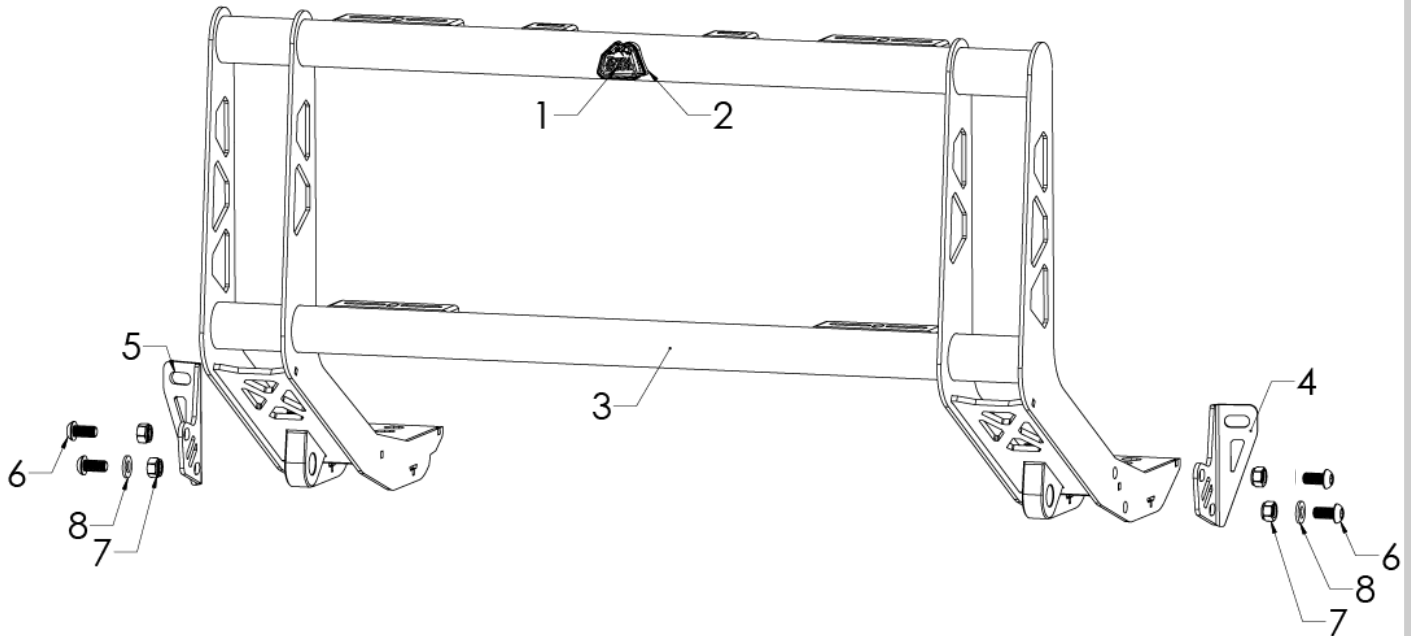

79-27030
aFe Power Terra Guard Bull Bar
Toyota Tacoma N400



Item	Description	P/N	Qty
1	Emblem, Terra Guard: 304SS (0.5mm 3M)	06-00238	1
2	Base, Terra Guard Badge, 2" OD	05-01791	1
3	Bull Bar, Assembly: Tacoma	05-61657	1
4	Bracket, LF Side, Bull Bar: 4Runner/Tacoma	05-61655	1
5	Bracket, RT Side, Bull Bar: 4Runner/Tacoma	05-61656	1
6	Screw, Button Head: M12 x 1.75 x 30mm SS Black	03-50813	4
7	Nut, Nylock: M12x1.75 SS Black	03-50814	4
8	Washer, Flat M12 SS Black	03-50815	2



- Please read the entire instruction manual before proceeding.
- Ensure all components listed are present.
- For technical support please call 951-493-7185.
- Ensure you have all necessary tools before proceeding.
- Retain factory parts for future use.

Procedure:

1. This installation can be done with the vehicle on the ground. But, for an easier installation, use a vehicle lift.



2. The bull bar primarily mounts to the factory tow hook locations but also utilizes side brackets that pick up from (2) of the crash beam bolts. The brackets require a small amount of plastic trimming on the bottom edge of the front bumper cover.

Here's a preview of how the bracket fits with the bumper trimmed:

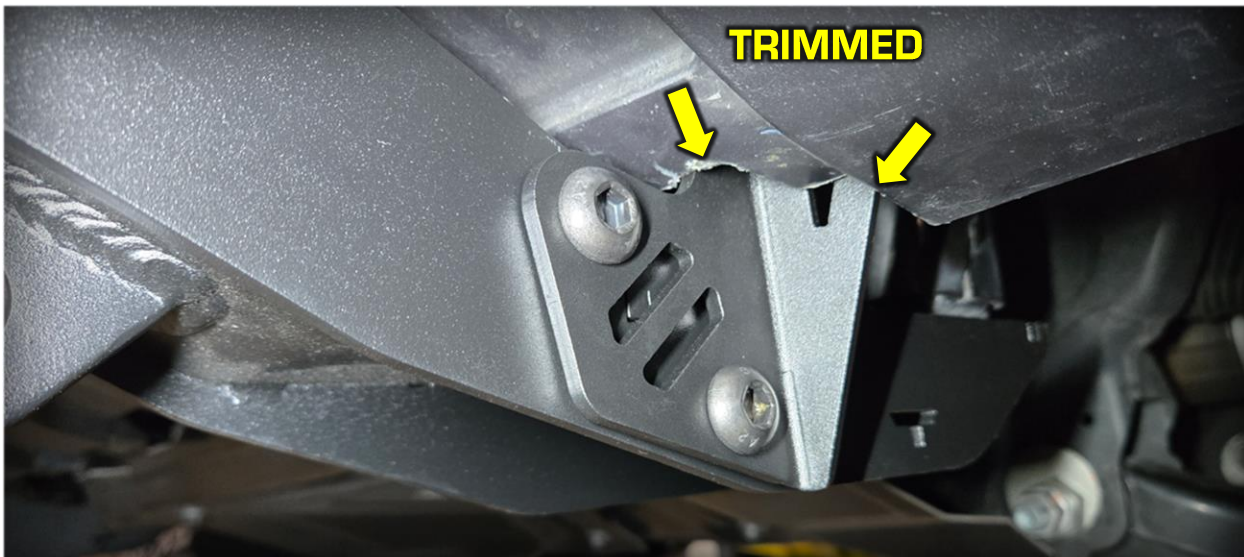



Use a Dremel with a cut off wheel to rough out the shape. Fine tune the cut with a barrel sander to radius the corners. You can position the brackets in that area to see if you clear. Cut little at a time.

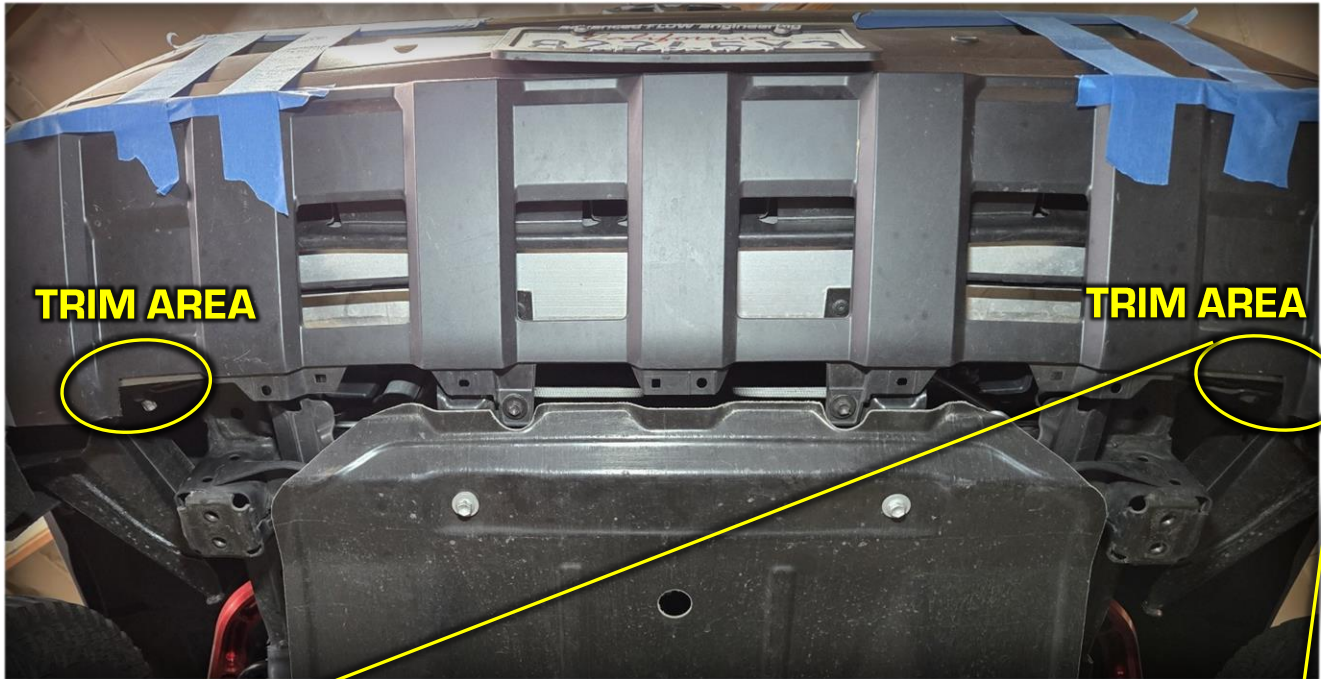

Driver side below.

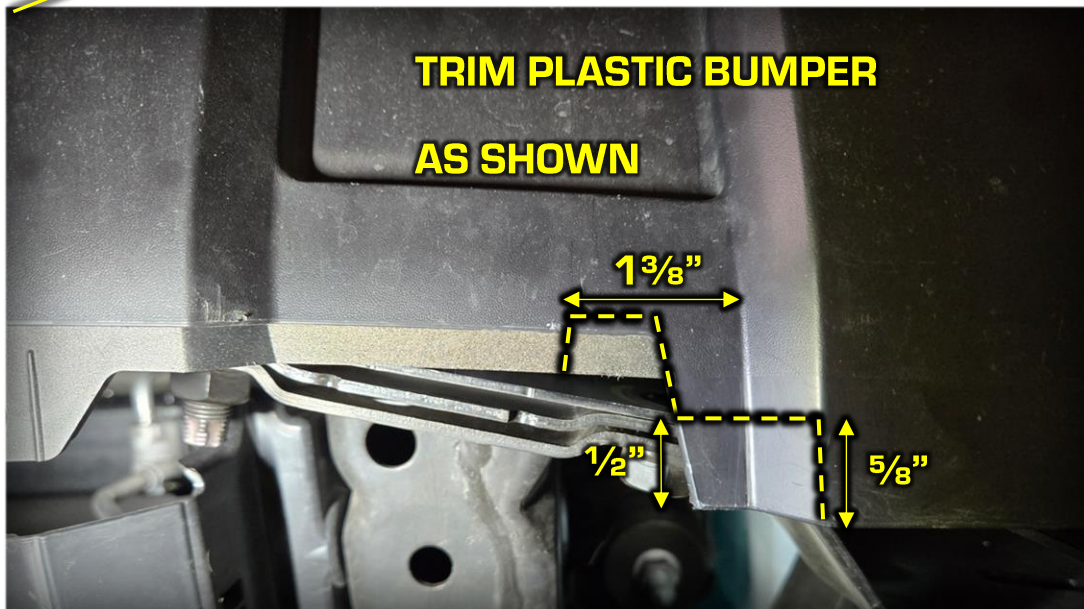

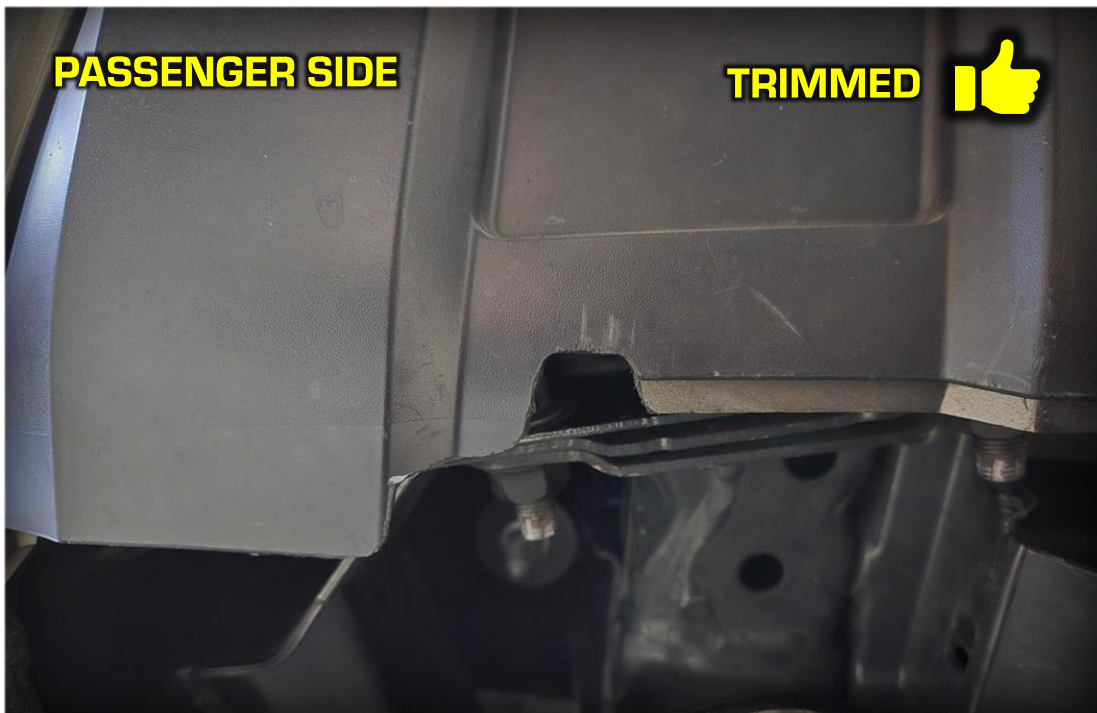
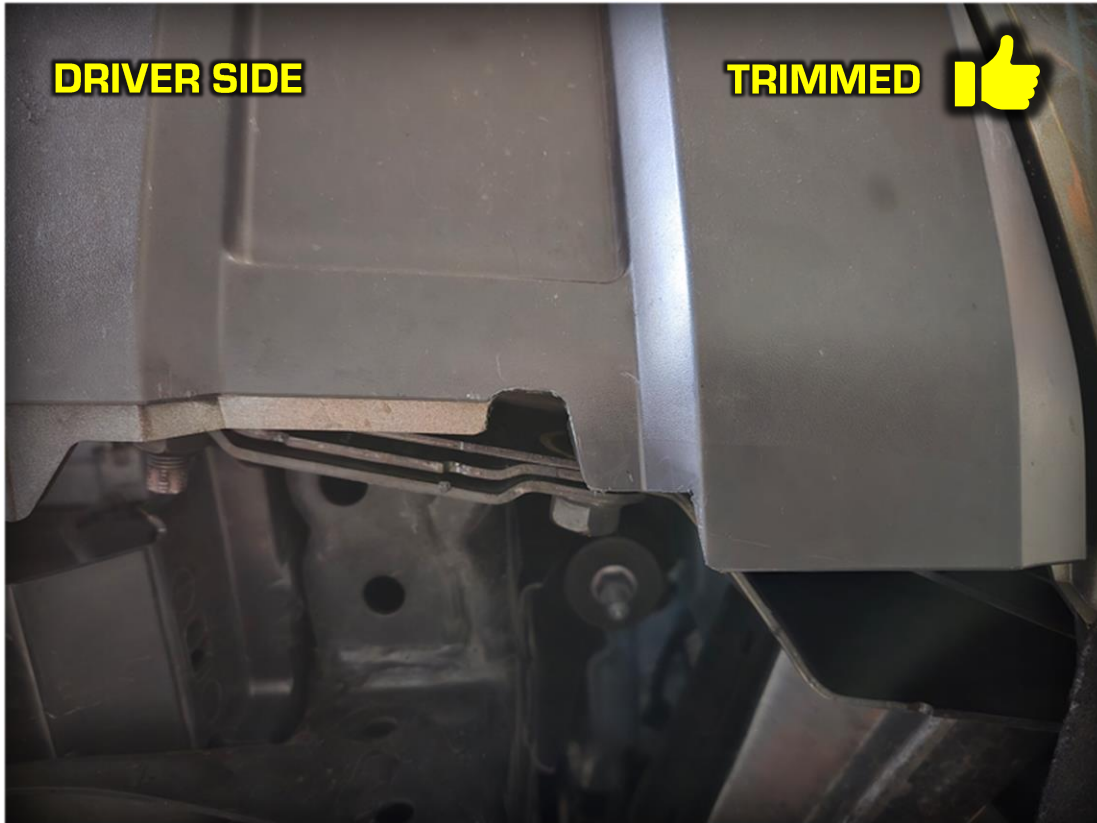



3. Remove the (2) black bolts near the center of the bottom edge of the bumper.

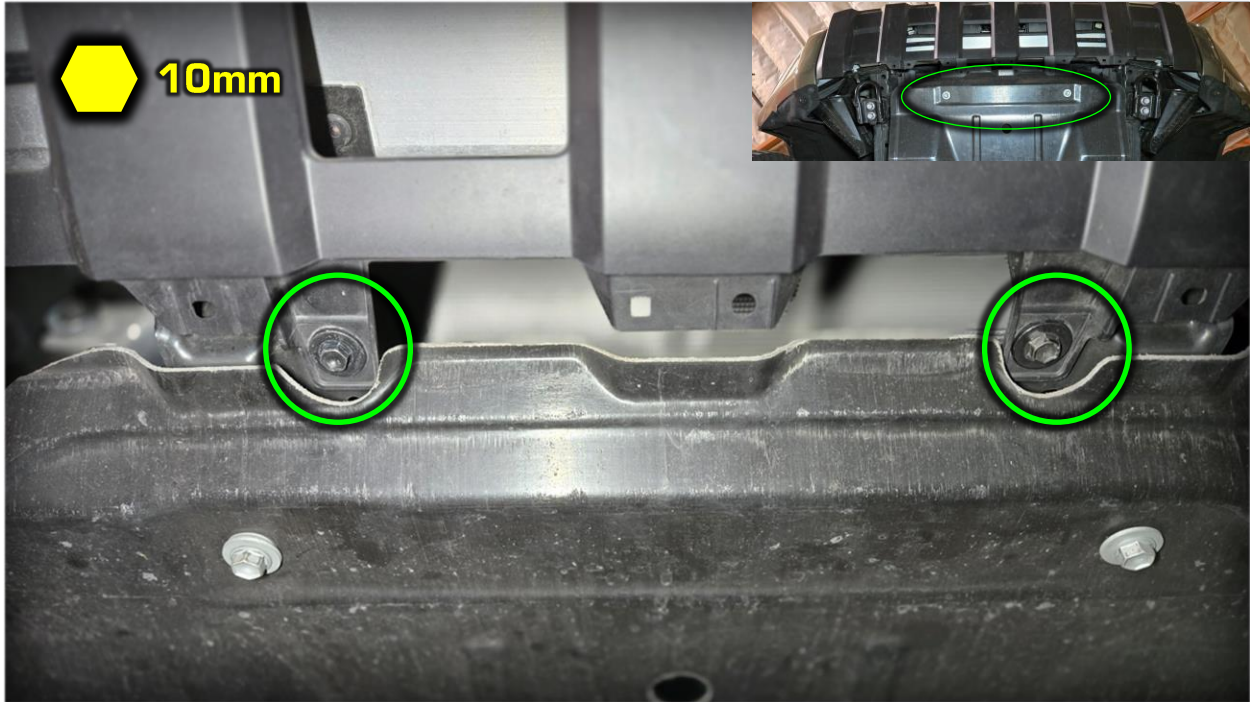

4. Remove the (2) black bolts at the bottom corner of the bumper. Perform this on both sides.

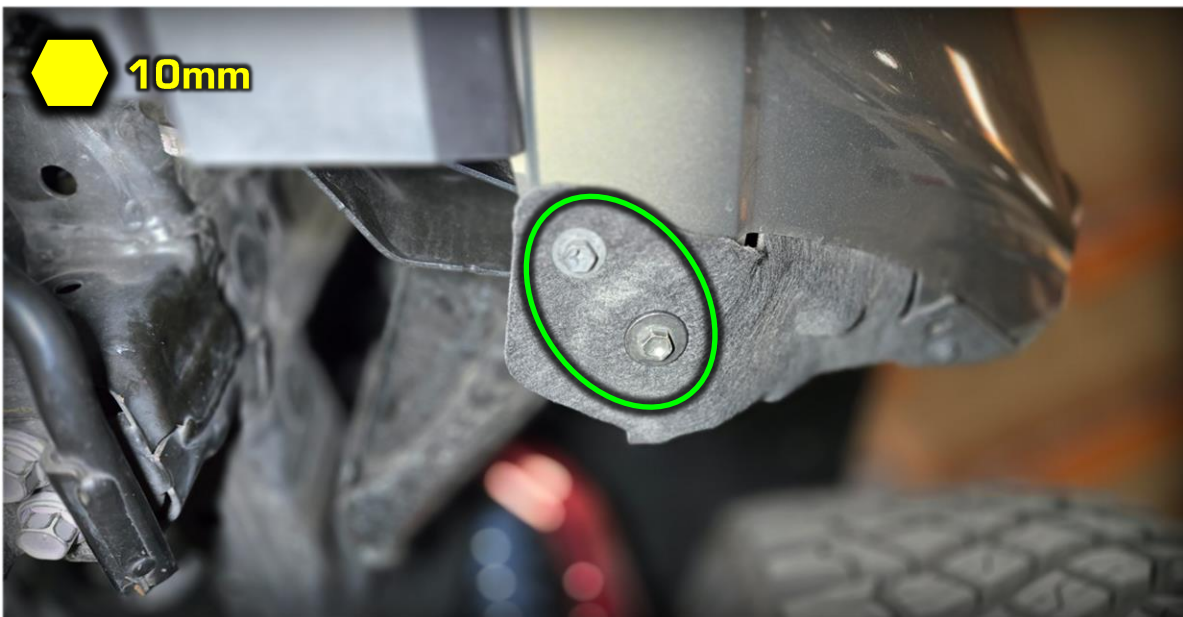



5. Undo (1) screw on each side, located just inside of the bottom edge of the bumper near the sides. You can see the screw when you look towards the front.

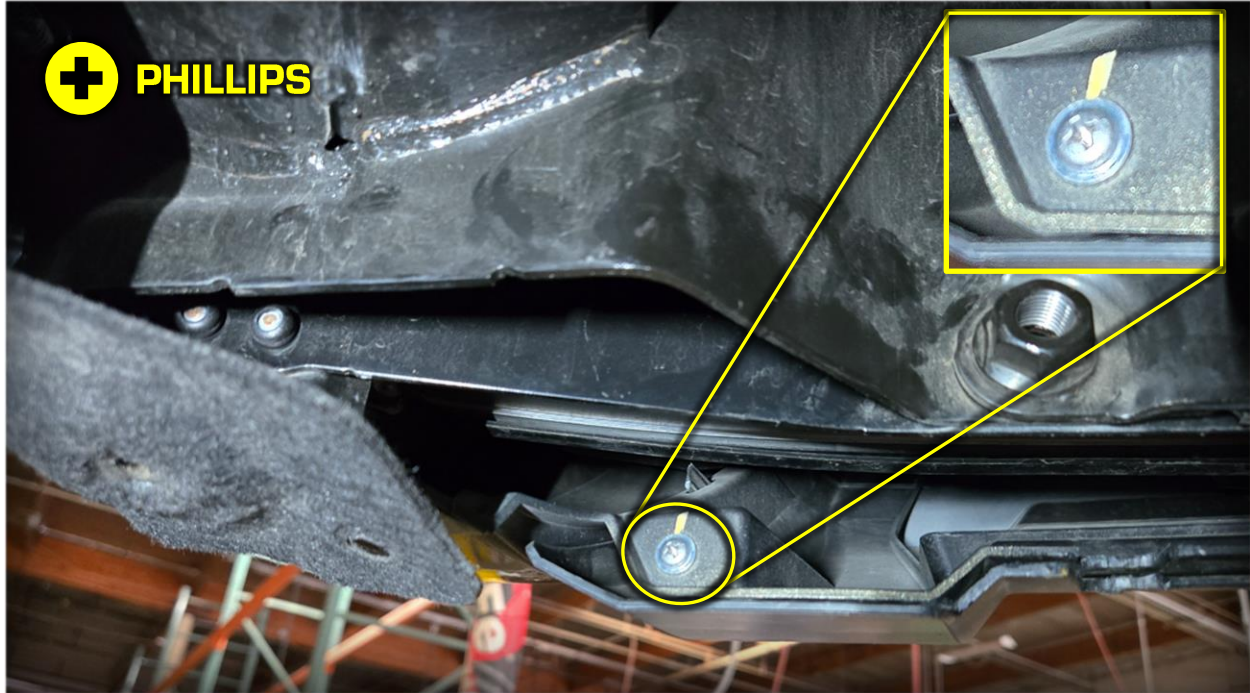

6. Locate the crash beam bolts on each side. With a ratcheting wrench, undo the **outer lower** crash beam bolt.



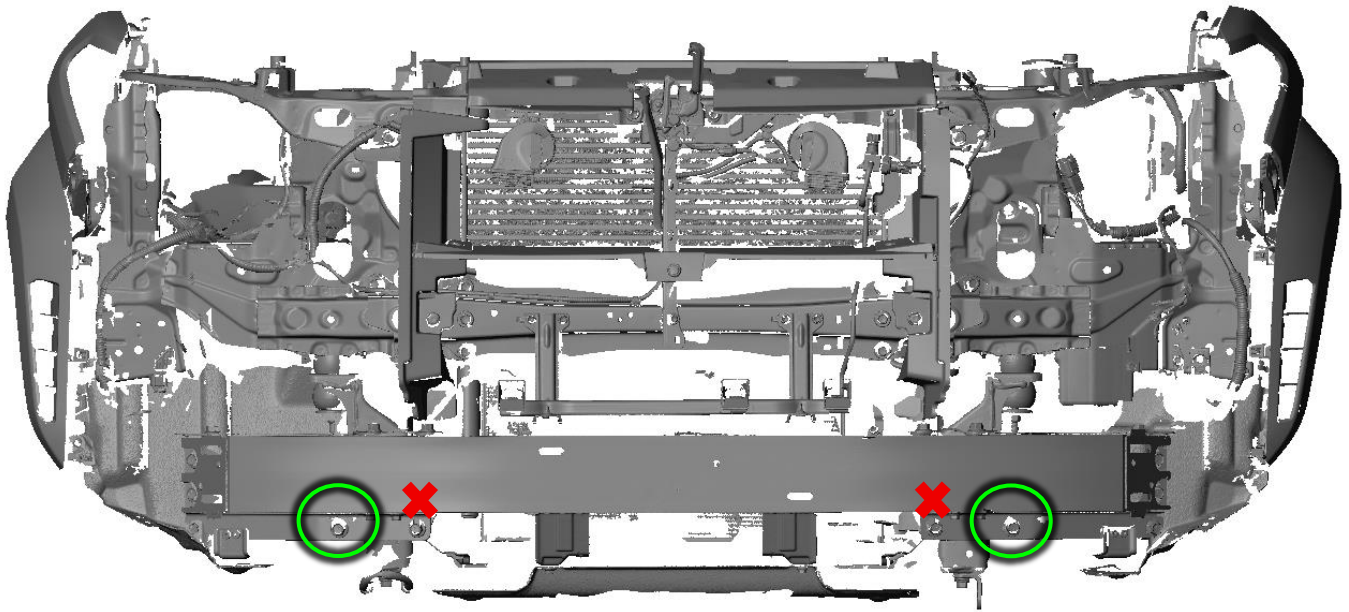



7. Install the aFe side bracket (05-61655) on the driver side and bracket (05-61656) on the passenger side. Install them loosely on the vehicle. Do not install them on the bull bar yet.

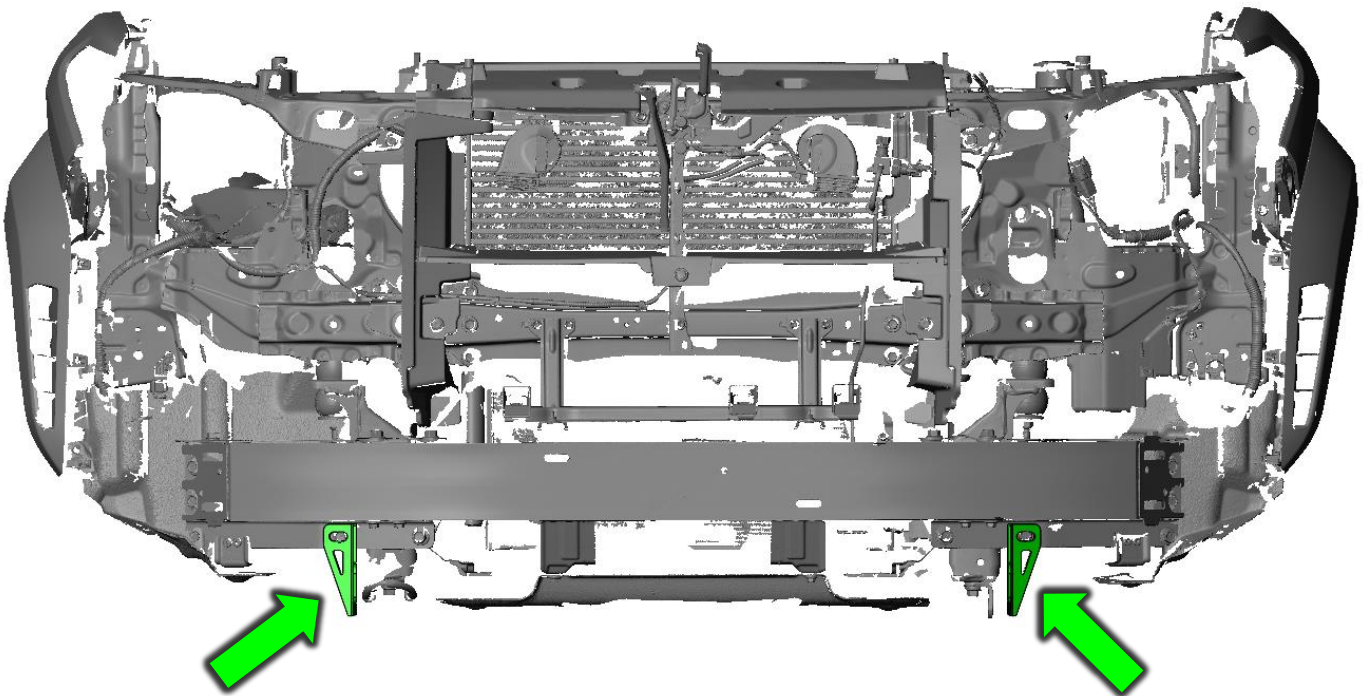
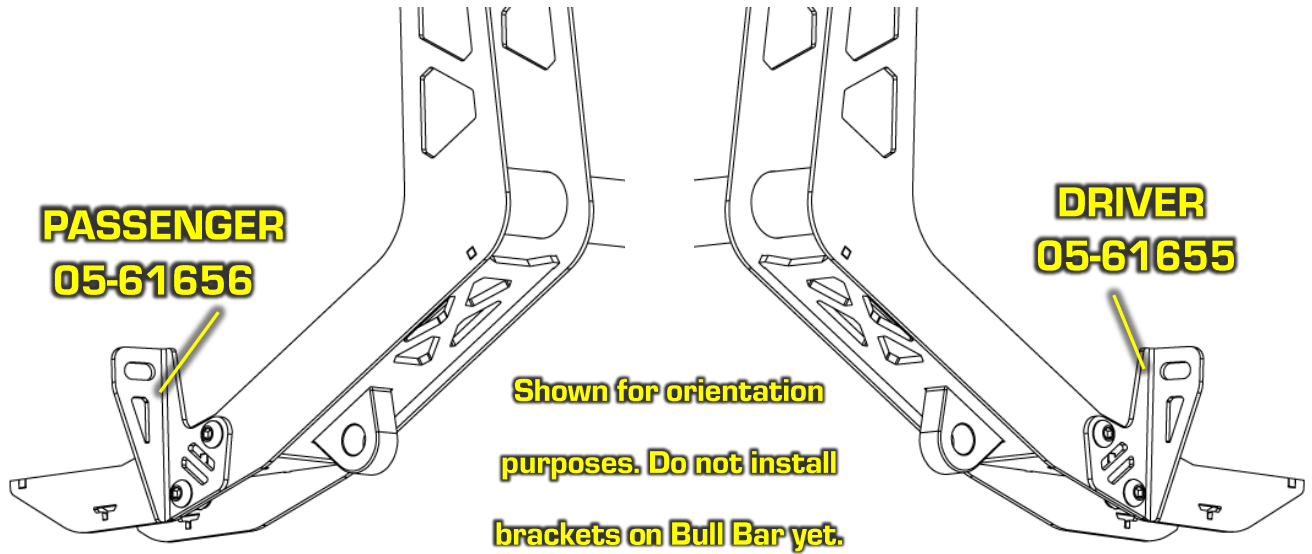



8. Position the bracket from the bottom up to the crash beam where you removed the bolt. Reinsert the OE bolt and tighten the bolt finger tight. Do this for the other side as well.

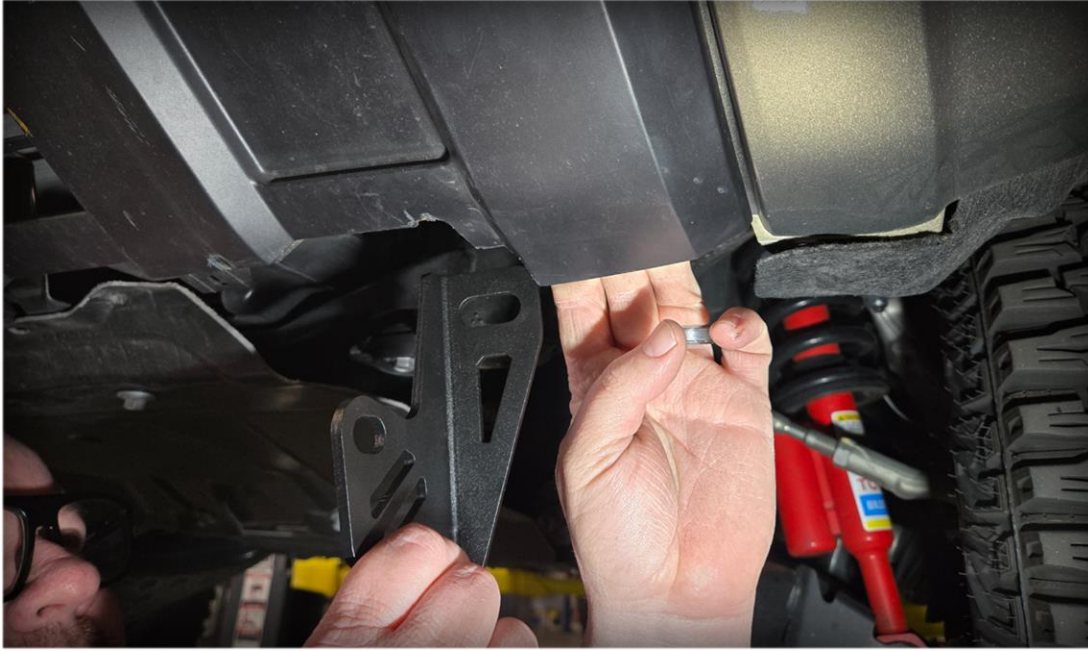



9. Next, remove the (2) bolts holding each of the factory tow hooks. Remove on both sides. Factory tow hooks will not be re-installed but keep hardware.

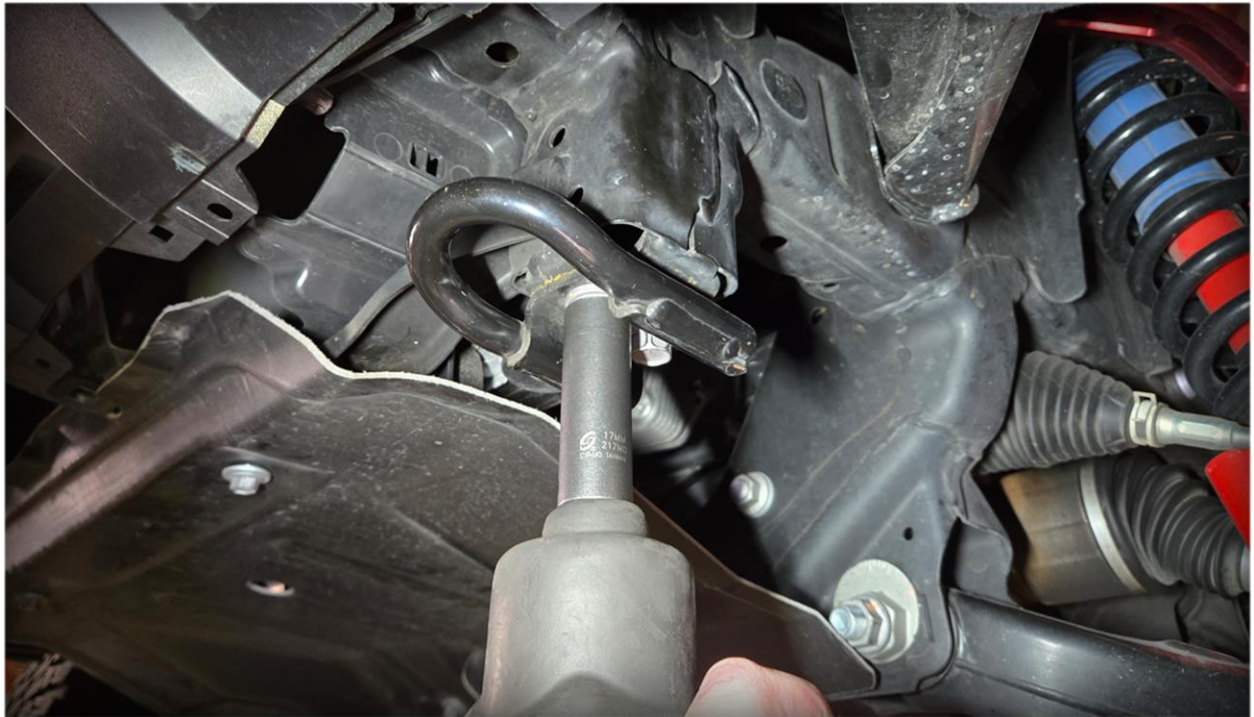
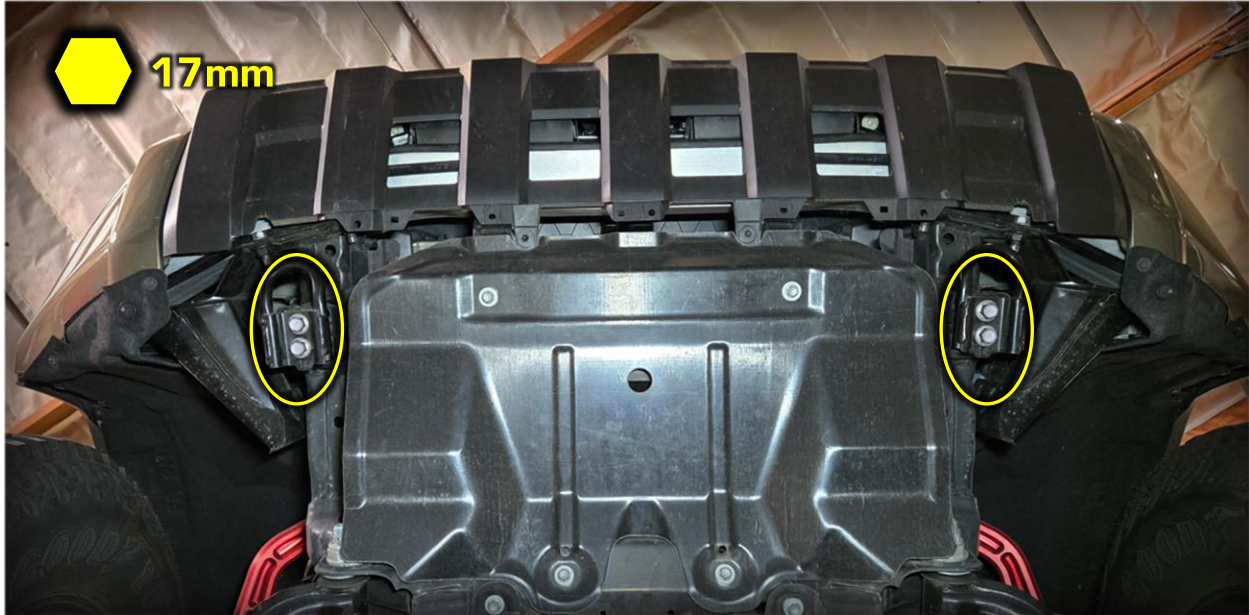



- Grab a buddy and lift the bull bar up to the car. Have the provided M12 button head bolts ready to install when lifting into place. Snug the tow hook bolts but do not fully tighten yet.



- Line up the side brackets to the bull bar and insert the button head bolts into the holes. *(Driver side shown)*





Install the washer and nylock nut on to the bottom bolts. Snug but do not fully tighten.



For the top bolt, insert the nut through the window of the bull bar (or reach around the back).

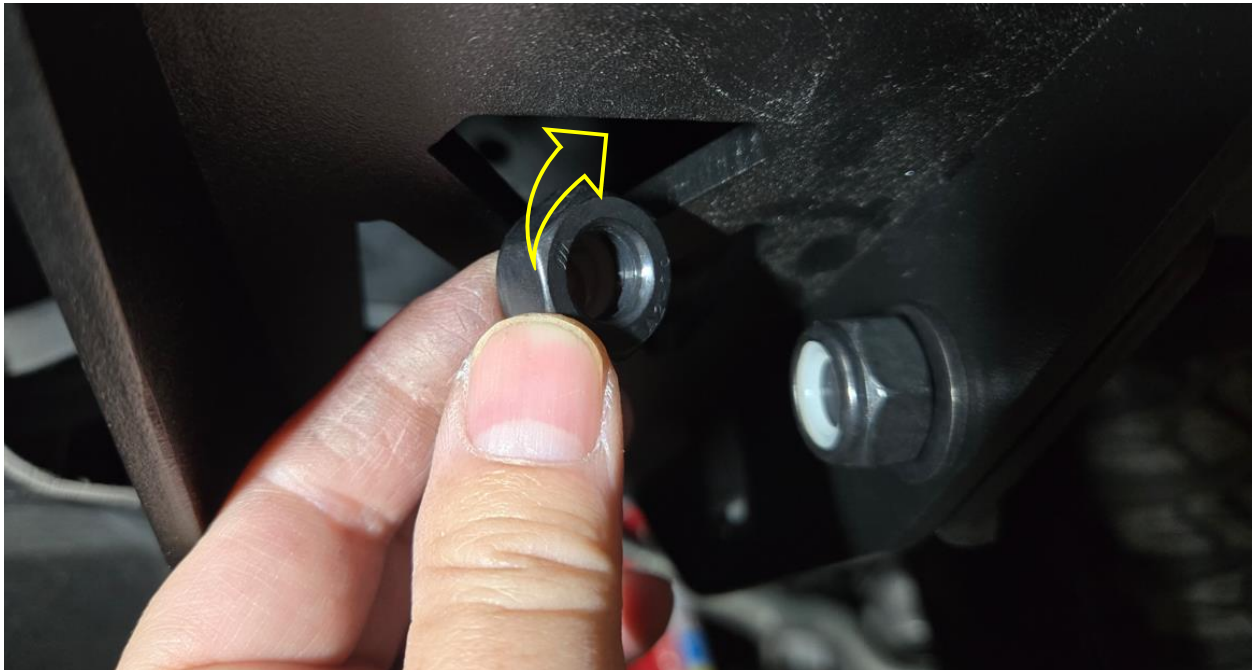



Guide the nut into the nut locker plate. Snug the bolt up but leave loose.

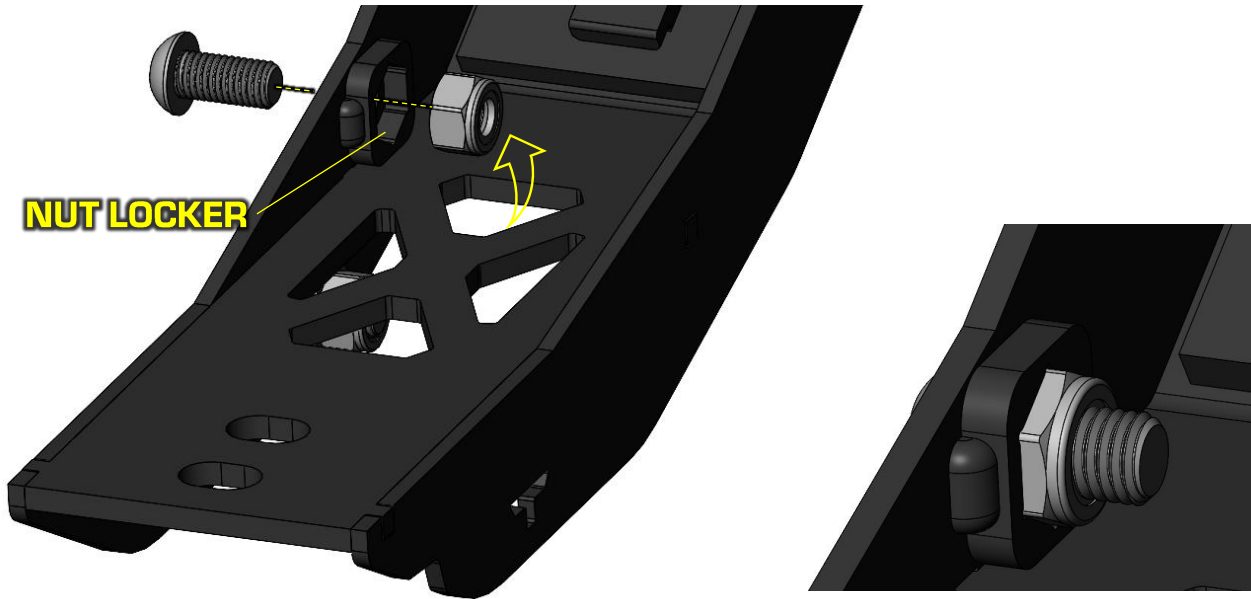

12. The slotted holes in the bull bar allow for some side to side adjustment. Center the bull bar with the bumper.





Fully tighten the tow hooks bolts to lock in the position. Torque to 90 ft lbs.



13. Tighten the crash beam bolts until the bracket is **snug but loose enough to move**.

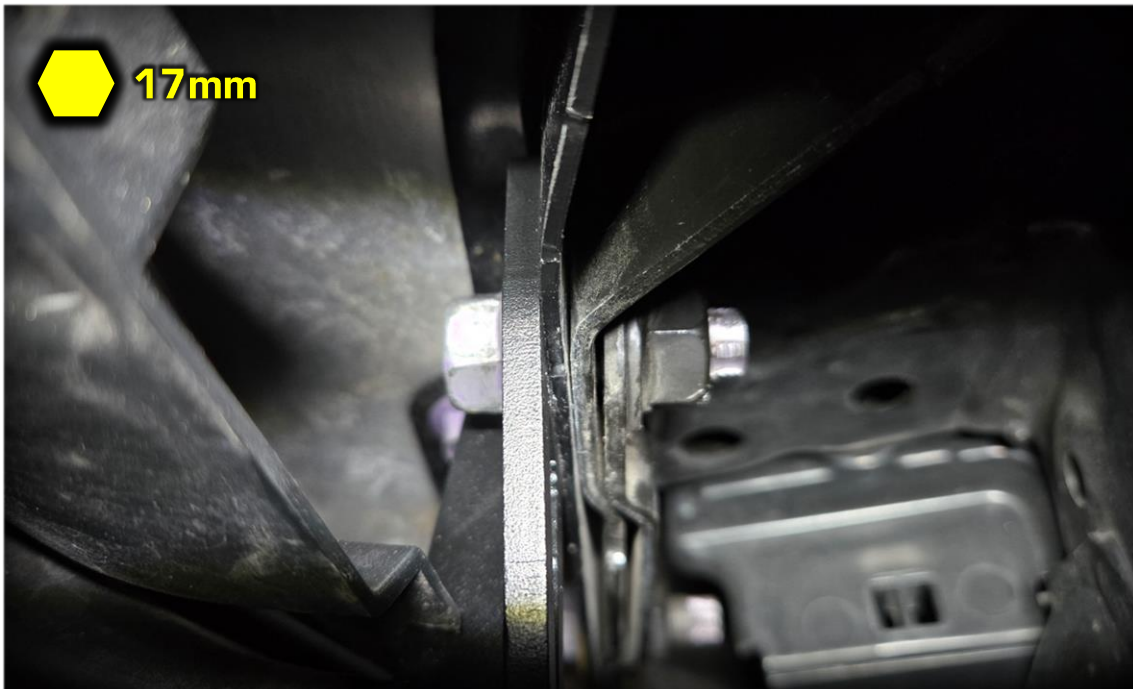



14. Next, tighten the side bracket button heads. Start by fully tightening the lower bolts.

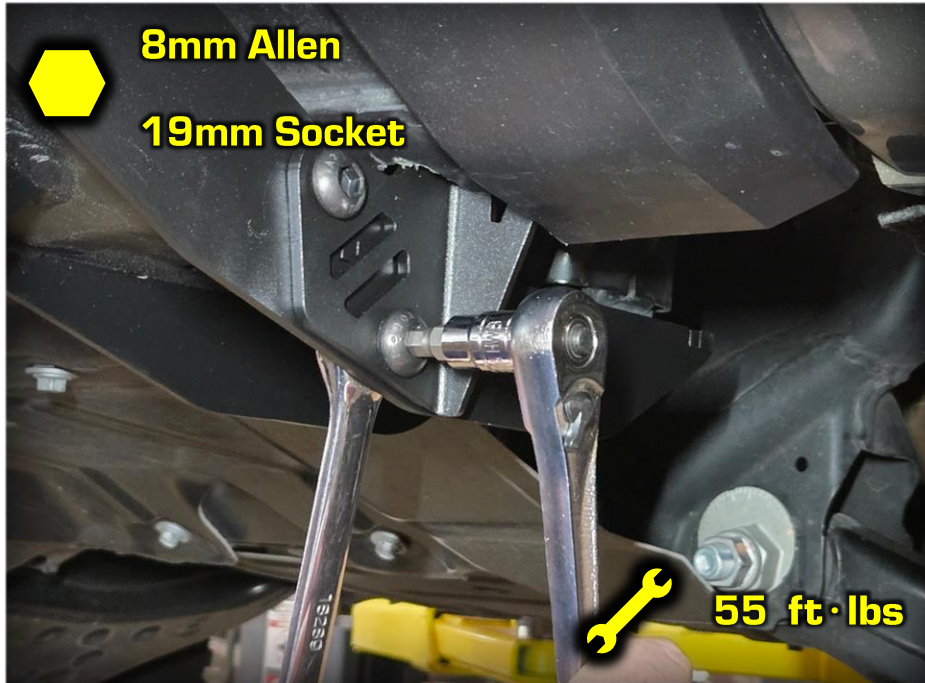

The top nut should be captured by the nut locker plate.

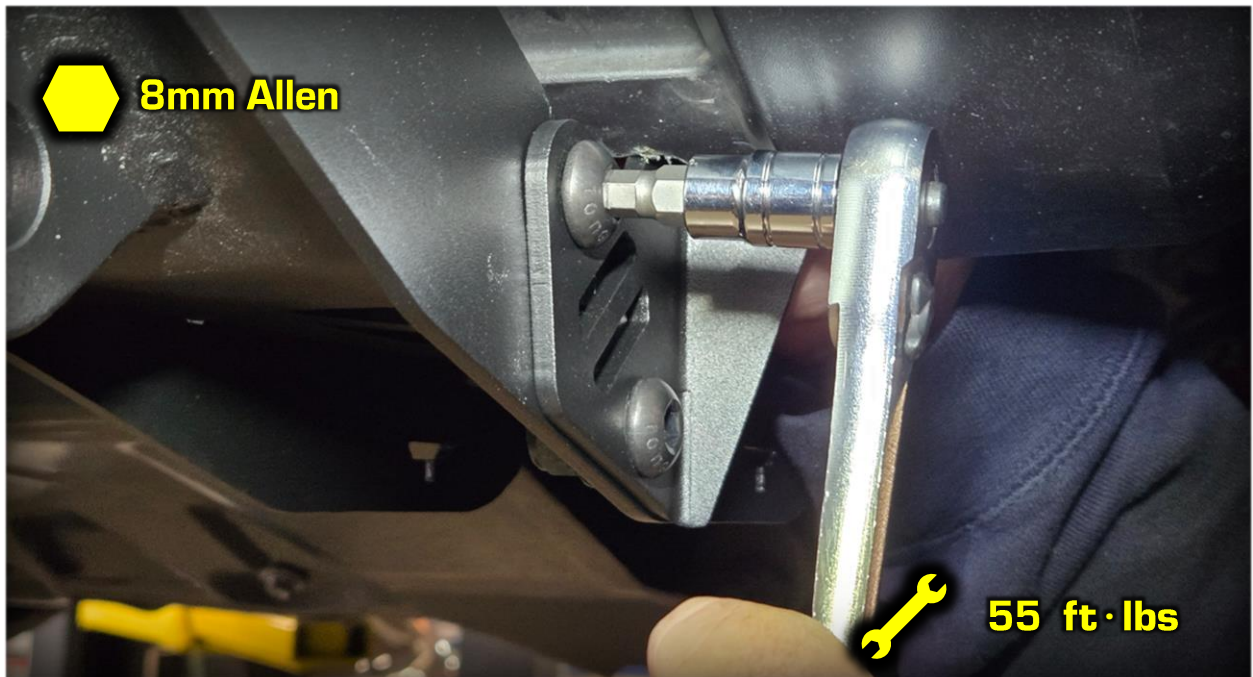



15. Next, fully tighten the crash beam bolts.

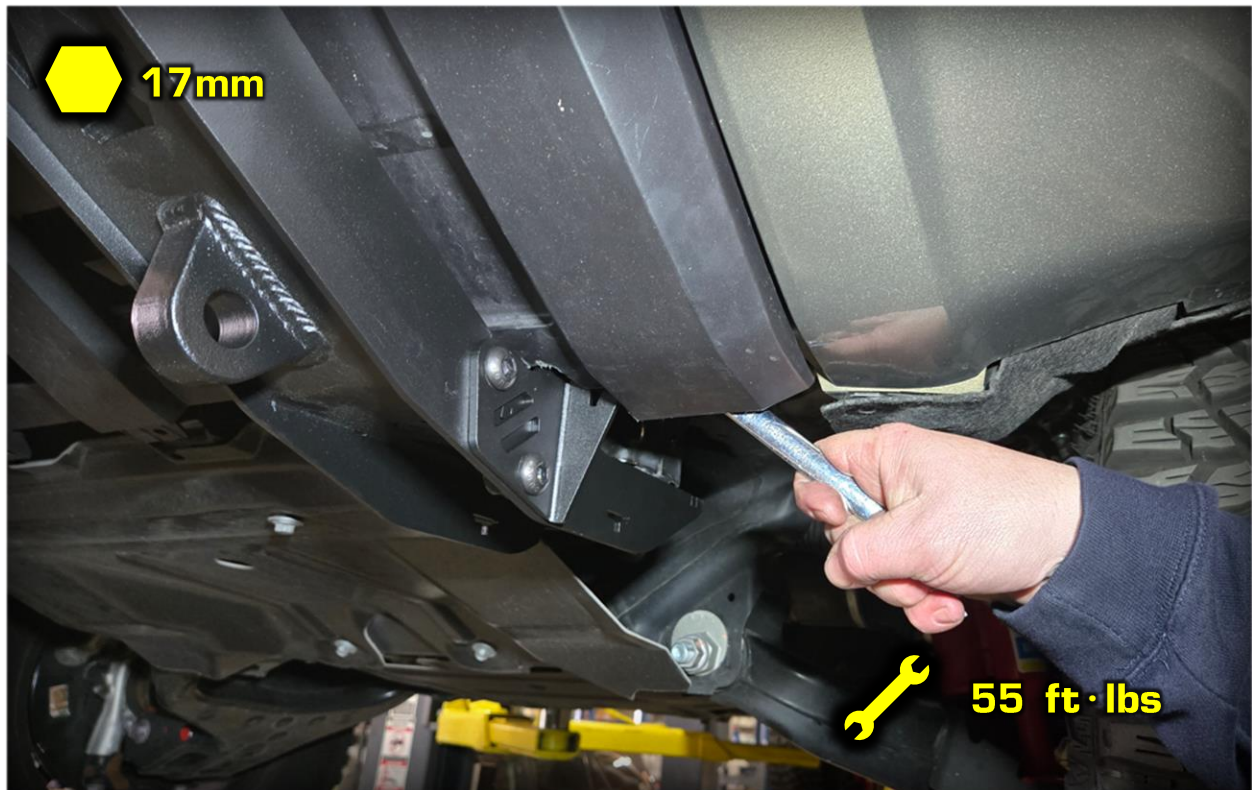

16. Repeat steps 3-5 in reverse order. You are finished with the bull bar installation. Move on to the next section for some lighting guidelines.



17. Lighting

When adding auxiliary lighting, please be aware of the location of the camera, radar, and parking sensors. Note, some trim models do not have front parking sensors. Our bull bar does provide mounting locations for lights that could potentially interfere with some of these sensors so please be aware of this possibility. However, the bull bar alone will not impact the function of rear parking sensors, adaptive cruise control, or other driver assistance features. Parking sensors can be turned off if you want to run lights on the bottom tube. Once you turn them off, they stay off. You do not have to worry about turning them off every key cycle. You do want to avoid mounting lights that could block the radar since this could affect safety driver assistance systems like emergency braking, lane departure, and adaptive cruise. If you mount a light bar underneath the top tube, make sure the mounts are low profile like our aFe power light bracket kit (**79-91002**) and use a light bar with a single-row form factor.





232 Granite St. Corona CA 92879 | aFePower.com | 951-493-7100



LEFT INTENTIONALLY BLANK



advanced FLOW engineering, inc.