

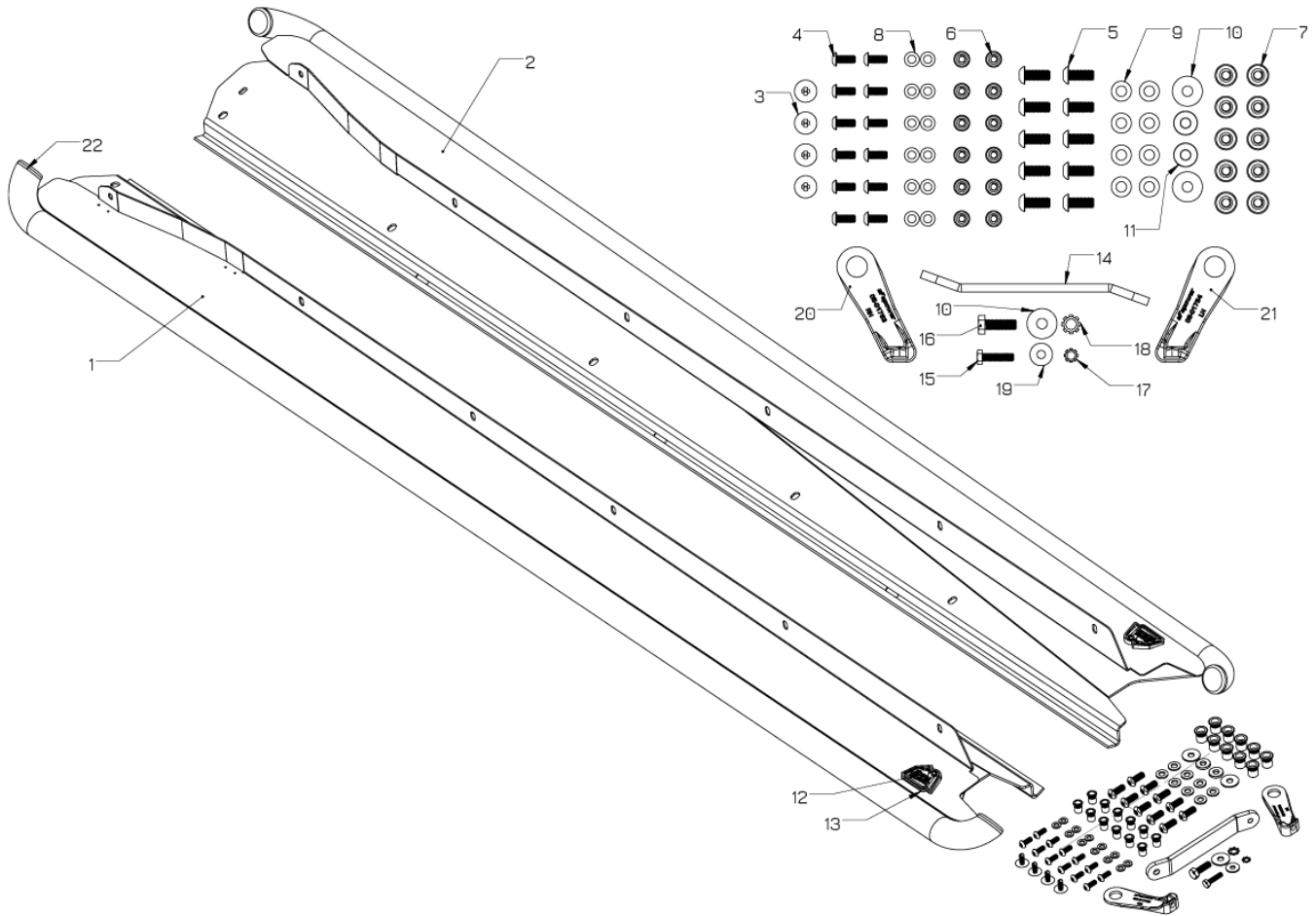

79-27003 aFe Power Terra Guard Off-Road Slider Subaru Outback 20+ BT Platform



Item	Description	P/N	Qty
1	RT Slider Assembly: BT Outback	05-61401	1
2	LF Slider Assembly, BT Outback	05-61402	1
3	Retainer Clip, Christmas Tree Style: 9/32" Hole	03-50616	4
4	Screw, Btn Hd Socket: M6x1x15, SS Black	03-50795	12
5	Screw, Btn Hd Socket: M8x1.25x20, SS Black	03-50796	10
6	Rivet, Nut: M6	03-50799	12
7	Rivet, Nut: M8	03-50798	10
8	Washer, M6 (12mm OD x 6.4mm ID)	03-50177	12
9	Washer, Flat M8: 16mm OD S/S	03-50159	8
10	Washer, Flat: 24mm ODxM8 ID	03-50065	3
11	Aluminum spacer 3/4 x 5/16 x 1/8	03-50800	2
12	Emblem, Terra Guard: 304SS (0.5mm 3M)	06-00238	2
13	Base, Flat Bottom, Terra Guard Badge	05-01748	2
14	Tool, Rivnut M6/M8	03-50801	1
15	Screw, Hex Head: M6x1x25mm	03-50114	2
16	Screw, Hex Head: M8x1.25x25mm	03-50421	2
17	Washer, Ext Star Lock M6	03-50803	1
18	Washer, Ext Star Lock M8	03-50804	1
19	Washer, Flat: M6	03-50070	1
20	Bracket, Mud Flap RT	05-01753	1
21	Bracket, Mud Flap LF	05-01754	1
22	Cap, Tube End: 20-23 Outback	05-01749	4



- Please read the entire instruction manual before proceeding.
- Ensure all components listed are present.
- For technical support please call 951-493-7185.
- Ensure you have all necessary tools before proceeding.
- Retain factory parts for future use.

Recommended Tools & Equipment:

- 3mm, 4mm, 5mm Allen Sockets. 10mm & 13mm Sockets. Panel removal tool. Floor ramps or 4-post lift.

Warranty Information available at <https://afepower.com/contact#warranty>

Procedure:

1. This installation can be done with the vehicle on the ground. But, for an easier installation, drive the vehicle onto floor ramps or 4-post rack.



2. Locate the side plastic rocker panel. Remove the (2) pop clips just behind the front wheel. If your vehicle is equipped with front mud guards, you will need to remove them.

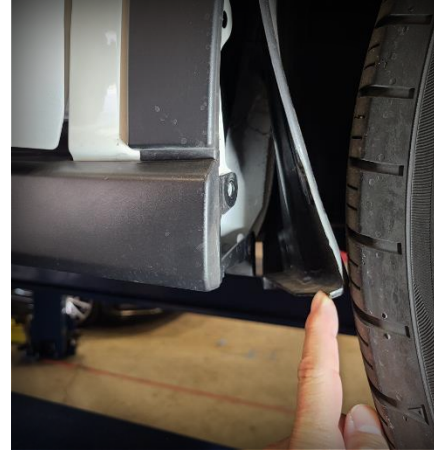

3. Remove the (6) pop clips at the bottom of the rocker panel.





4. Use a panel removal pry tool to separate the top portion of the panel away from the body. Panel should be free from the car.



5. There is a rubber flap near the rear of the rocker. Remove the pop clip to allow the rubber flap to pull away from the bottom.



6. **(Optional)** At this point you can choose to paint the lower portion of the rocker black to make the installation look seamless. Mask above the reference line indicated below. Scuff the paint with a Scotchbrite pad and clean with isopropyl alcohol. Truck bed liner works well for this application.





- Next, install the rivet nuts. The (6) M6 rivet nuts will go on the top vertical portion of the rocker and the (5) M8 rivet nuts will install on the bottom section of the panel.

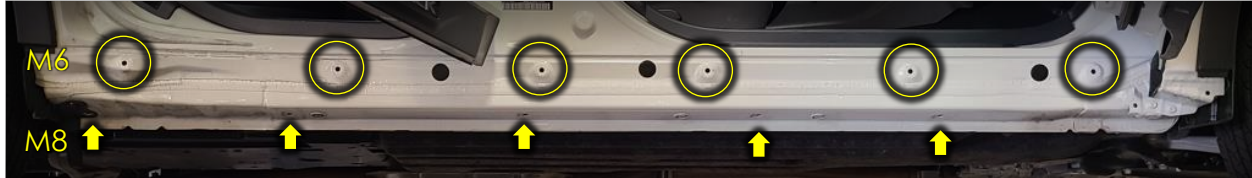

Important Note:

Installing the rivet nuts is by far the trickiest part of this installation. Professional installation is highly recommended. If installing rivet nuts for the first time, purchasing a rivet nut setting tool is recommended. (see below) They are reasonably priced and available at your local hardware store or Amazon.



Rivet Nut Setting Tool (not included)

Your kit does include a rivet nut tool that works great when used with care. If you decide to use our tool, follow the procedure below.

- Insert the rivet nut into the hole flush to the panel.
- Install the appropriately sized hex bolt and washer on the top end of the tool. Grease/oil the surface where the head and washer meet.
- Install the star lock washer onto the bolt at the bottom of the tool. The star washer has a smooth side and a sharp side. Make sure the sharp side is facing the rivet nut. **Grease/oil the threads of the bolt.**
- Thread the bolt into the rivet nut, sandwiching the star washer. Once everything is finger tight, use a **10mm** or **13mm** socket and torque wrench to tighten the bolt while holding the tool stationary. The bolt should spin while rivet nut forms in place.
- Tighten until you reach **6 ft-lbs** for the **6mm** bolts and **8 ft-lbs** for the **8mm** bolts.
- Unscrew the bolt and move on to the next. Your kit includes a pair of each size bolt so you can use one bolt to set the rivet nuts for the driver side and one for the passenger side.

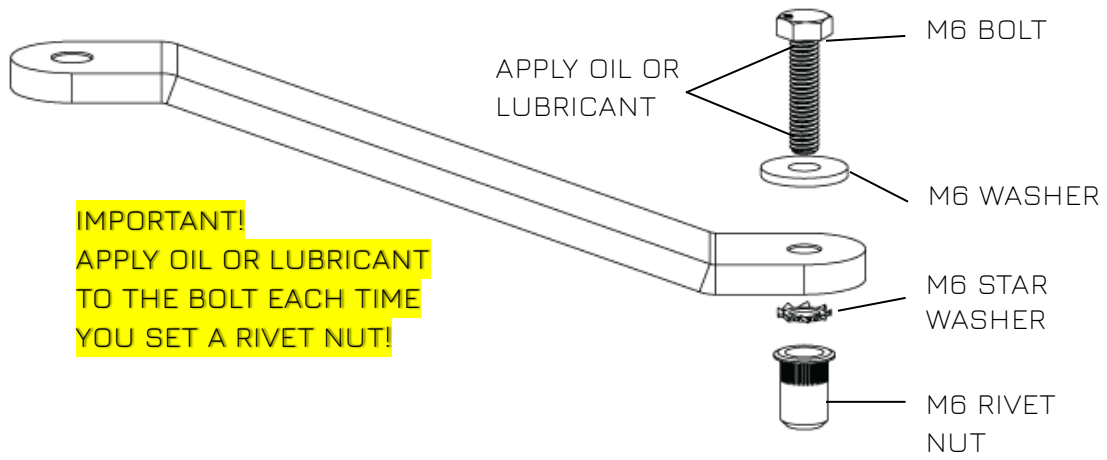

IMPORTANT!
APPLY OIL OR LUBRICANT
TO THE BOLT EACH TIME
YOU SET A RIVET NUT!





8. Install the Slider onto the car. Start attaching the bottom with the M8 button heads (item #5) with the M8 washers (item #9) loosely. These panels can be heavy, so it helps to have another person hold one end when installing.

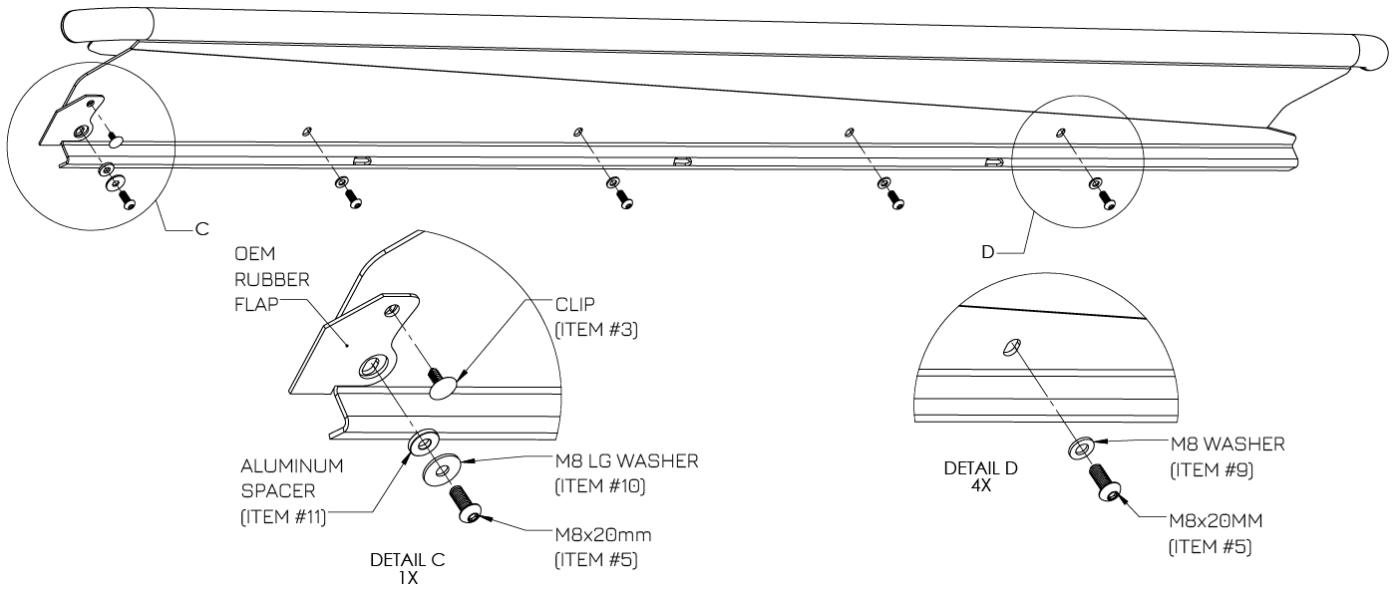

The OEM rear rubber flap will reside over the step panel so when you get to the last rearward bolt you will place the aluminum spacer (item #11) in the flap hole and larger M8 washer (item #10) to secure the rubber flap in place. Install the provided push retainer clip (item #3) into the smaller hole to further secure the rubber flap.

Next, start attaching the top panel with the M6 button heads (item #4) and M6 washers (item #8). Remember to keep all bolts loose to make it easier to start all of the fasteners.

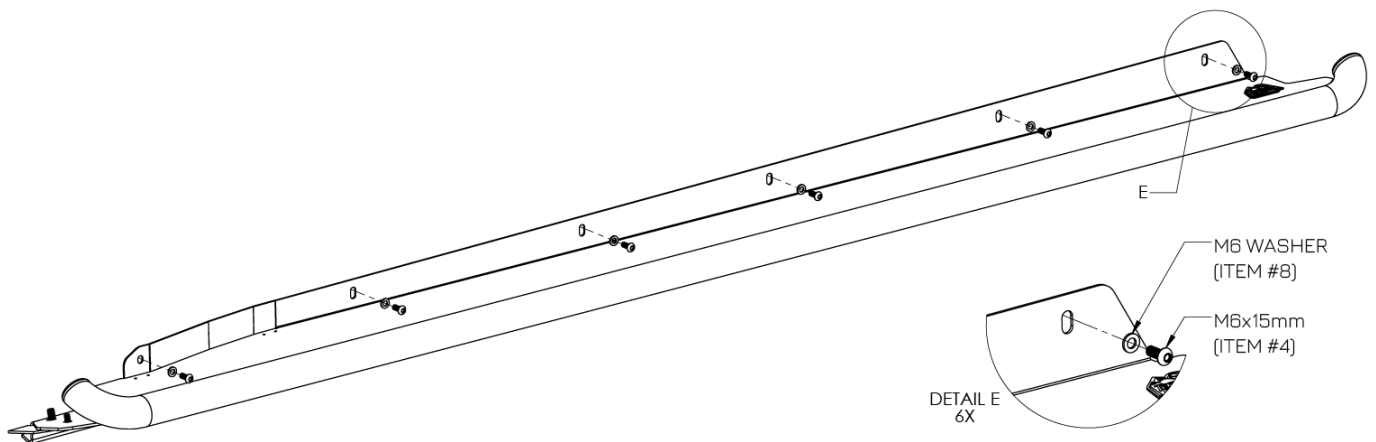



9. Once all of the bolts are started, we will tighten all of the fasteners. First, tighten the bottom panel **M8 bolts (12 ft-lbs)** and then work your way up to the top **M6 bolts (7 ft-lbs)**. Tightening out of sequence may twist the step from its intended shape.
10. Lastly, we will install the mud flap brackets in the front. Reuse one of the original factory pop-clip from the OEM rocker cladding to secure the mud flap bracket (Items #20,21) to the body. The provided push clip can be used to secure the OEM mud flap or to secure the inner fender liner alone. Aftermarket mudflap may need additional hardware (suggest: M6-1x25mm button head bolt with hex nut). Bracket is designed to accept an M6 nut and shape will keep the nut from spinning.

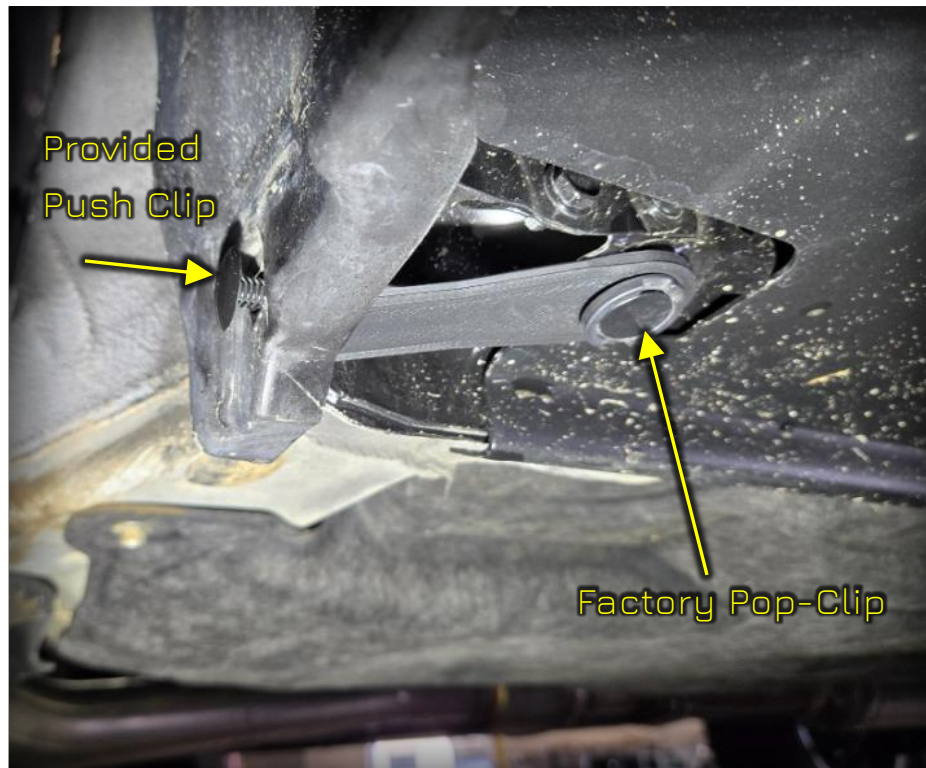



advanced FLOW engineering, inc.