

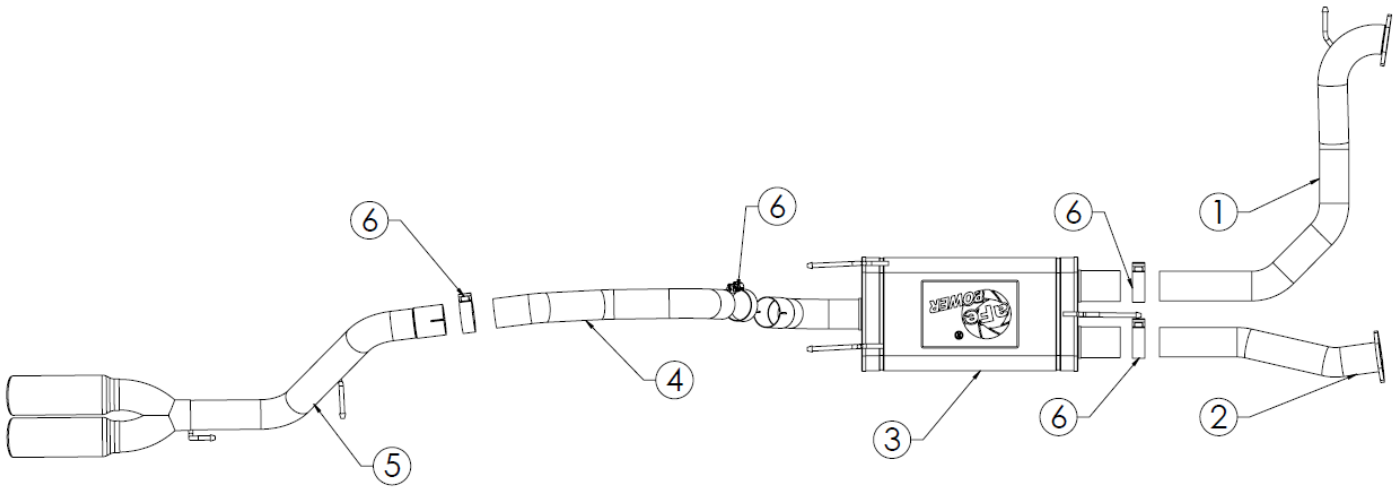

INSTALLATION INSTRUCTIONS

MAKE: Nissan
MODEL: Armada
YEAR: 2025-2026
ENGINE: V6-3.5L(tt)

Cat-Back Exhaust
49-36143-B (Black Tip)
49-36143-P (Polished Tip)



| Item | Description | Part Number | Quantity |
|-------------|-----------------------------------|--------------------|-----------------|
| 1 | S/A DS Front Pipe | 05-245674 | 1 |
| 2 | S/A PS Front Pipe | 05-245675 | 1 |
| 3 | S/A Muffler Assembly | 05-245677 | 1 |
| 4 | S/A Over-Axle | 05-245678 | 1 |
| 5 | S/A Tailpipe with black Tip | 05-245680B | 1 |
| 6 | S/A DS Tailpipe with Polished Tip | 05-245680P | 1 |
| | Clamp, Band: 3" | 05-41055 | 4 |

aFe POWER recommends professional installation on this product. Thoroughly inspect the aFe POWER exhaust system to make sure there is no damage from shipping (if damage is noted, immediately contact aFe POWER customer service). Allow time for your vehicle to cool down prior to installation. When working on your vehicle proceed with caution. Wear protective safety equipment; eye goggles and gloves to ensure a safe installation.

Install band clamps to proper torque specifications of 40-45 ft-lb.





INSTALLATION INSTRUCTIONS

MAKE: Nissan
MODEL: Armada
YEAR: 2025-2026
ENGINE: V6-3.5L(tt)

Cat-Back Exhaust
49-36143-B (Black Tip)
49-36143-P (Polished Tip)

1. **(Read instructions prior to installation.)** It is recommended to not fully tighten the exhaust until it has been fully installed. Leave loose for adjustability.
2. Secure vehicle on jack stands (refer to your manual for specified jack stand positions).
3. For faster installation, spread out the parts of the exhaust alongside your vehicle as shown in the diagram above.
4. Secure the stock exhaust with jack/stands.
5. Remove the bolts and springs at the front of the vehicle's exhaust. Retain the hardware, it will be re-used for installation of the aFe POWER exhaust.
6. Remove the OE exhaust hangers from the isolators. Be careful to not damage the isolators and remove O.E Exhaust.
7. Install the DS/PS front pipes on to the Muffler Assembly using the supplied 3" band clamp. Do not fully tighten band clamp to allow for adjustment (install on floor before installing on vehicle for easier assembly).
8. Install the front pipes and Muffler assembly onto the catalytic converters using O.E hardware and provided nuts. Install the hangers of the muffler assy. And DS front Pipe onto the vehicle's isolation mounts.
9. Install the over-axle pipe with the supplied 3" band clamp and install hanger onto isolator mount.
10. Install the tail-pipe assembly with the supplied 3" band clamp and install the hanger into the vehicle's isolator mount.
11. Ensure that all the components of the aFe POWER exhaust system are aligned and are at a safe clearance from all wires, hoses, brake lines, body parts, and tires.
12. Start from the front of the aFe exhaust system and evenly tighten all clamps and fasteners.
13. Start the vehicle and check for any leaks. If any leaks are found, determine cause and repair as necessary.
14. Remove vehicle from jacks stands.
15. It is recommended to re-tighten all clamps and hardware after 50-100 miles.