

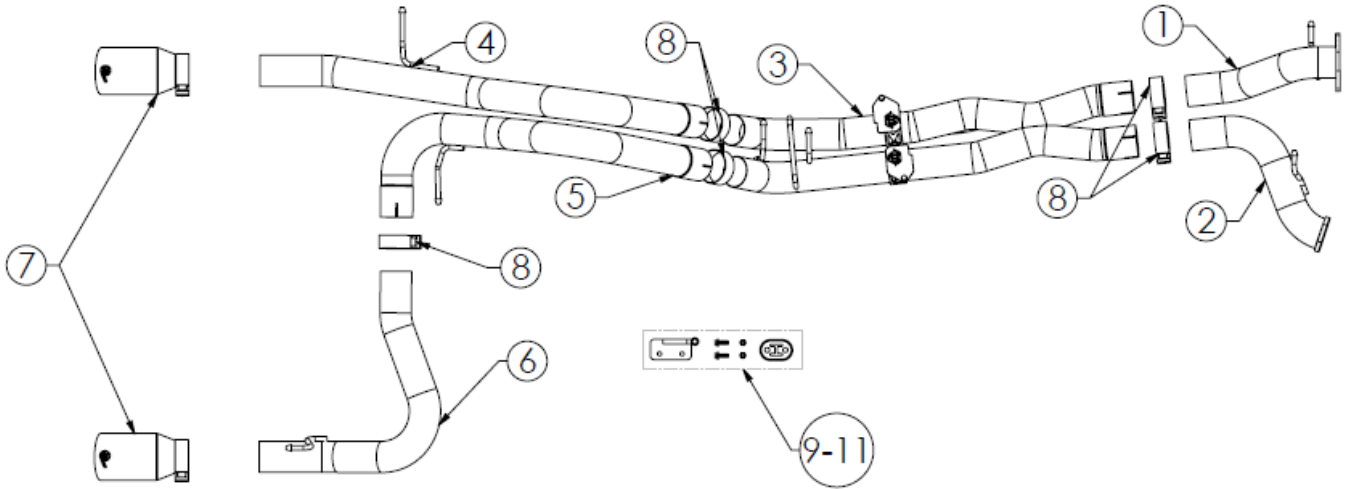

INSTALLATION INSTRUCTIONS

MAKE: Ford
MODEL: Bronco Raptor
YEAR: 2022-2026
ENGINE: V6-3.0L (tt)

Cat-Back Exhaust
 49-33154-B (Black Tip)
 49-33154-P (Polished Tip)



Item	Description	Part Number	Quantity
1	S/A Front-Pipe DS	05-245653	1
2	S/A Front-Pipe PS	05-245654	1
3	S/A Expansion Chamber Assy	05-245655	1
4	S/A Tailpipe DS	05-245658	1
5	S/A Over-Axle PS	05-245659	1
6	S/A Tailpipe PS	05-245660	1
7	EXH Tip 3 In x 4-1/2 Out x 9L Bolt-On Blk	49T30454-B092	2
7	EXH Tip 3 In x 4-1/2 Out x 9L Bolt-On Pol	49T30454-P092	2
8	Clamp, Band: 3"	05-41055	5
9	Hanger Bracket	05-410524	1
10	Bolt, M8 x 1.25 x 25mm	03-50442	2
11	Nut, M8 x 1.25	03-50403	2
12	Isolation Mount: Rubber	05-46050	1

aFe POWER recommends professional installation on this product. Thoroughly inspect the aFe POWER exhaust system to make sure there is no damage from shipping (if damage is noted, immediately contact aFe POWER customer service). Allow time for your vehicle to cool down prior to installation. When working on your vehicle proceed with caution. Wear protective safety equipment; eye goggles and gloves to ensure a safe installation.

Install band clamps to proper torque specifications of 40-45 ft-lb.





INSTALLATION INSTRUCTIONS

MAKE: Ford
MODEL: Bronco Raptor
YEAR: 2022-2026
ENGINE: V6-3.0L (tt)

Cat-Back Exhaust
49-33154-B (Black Tip)
49-33154-P (Polished Tip)

1. **(Read instructions prior to installation.)** It is recommended not to fully tighten the exhaust until it has been fully installed. Leave loose for adjustability.
2. Secure vehicle on jack stands (refer to your manual for specified jack stand positions).
3. For faster installation, spread out the parts of the exhaust alongside your vehicle as shown in the diagram above.
4. Secure the stock exhaust with jack/stands.
5. Start by loosening Tailpipe clamps and Un-Bolt the Rubber Hanger Mounts for easier removal of O.E. exhaust (Keep note of hanger mount locations and placement). Retain Mounts and bolts, remove O.E. tailpipes
6. Unplug the electrical connections to the valves and loosen slip/band clamps. Then Un-Bolt the Rubber Hanger Mounts for easier removal of O.E. Muffler assembly.
7. Remove the exhaust valve motors from the O.E. exhaust and install on to the aFe Power Exhaust using the O.E. hardware. To Install O.E valve motor into aFe Expansion chamber assembly Top/Bottom place valve, on valve Assy and then push and turn clockwise till bolt mounts line up. Then use O.E bolts to install valve (valve should stay in place if installed correctly).
8. Reinstall all Rubber hangers mount on to aFe Exhaust.
9. Install Drivers side and passenger side front pipes on to aFe power Expansion Chamber Assy first before installing onto vehicle for easier installation.
10. Install aFe Power Expansion Chamber assembly/front pipes using the O.E. Hardware for the flanges and install all rubber mount insulators onto vehicle. Plug in electrical connections on to valves. install the Rubber mount isolator
11. Install aFe Power Drivers side Tailpipe with provided 3" band clamps then install the rubber mount isolator
12. Install aFe Power Passenger side Over-Axle with provided 3" band clamps then install the rubber mount isolator
13. Install Hanger Bracket mount onto frame using provided hardware (use photos below as reference). Once hanger mount is installed please install isolation mount to hanger mount bracket.





INSTALLATION INSTRUCTIONS

MAKE: Ford
MODEL: Bronco Raptor
YEAR: 2022-2026
ENGINE: V6-3.0L (tt)

Cat-Back Exhaust
49-33154-B (Black Tip)
49-33154-P (Polished Tip)

14. Install aFe Power Passenger side Tailpipe with provided 3" band clamps then install the rubber mount isolator
15. Adjust System for alignment and tighten all clamps
16. Ensure that all the components of the aFe POWER exhaust system are aligned and are at a safe clearance from all wires, hoses, brake lines, body parts, and tires.
17. Start from the front of the aFe POWER exhaust system and evenly tighten all clamps and fasteners.
18. Start the vehicle and check for any leaks. If any leaks are found, determine cause and repair as necessary.
19. Remove vehicle from jacks stands.
20. It is recommended to re-tighten all clamps and hardware after 50-100 miles

