

aFe CONTROL *Sway Bar Set* *2015-2021 Volkswagen GTI*

Product Number: 440-611001-L, 440-611001FL, 440-611001RL

Install Time: 5 hrs. (Full Kit), 4 hr. (Front Kit), 1 hr. (Rear Kit)

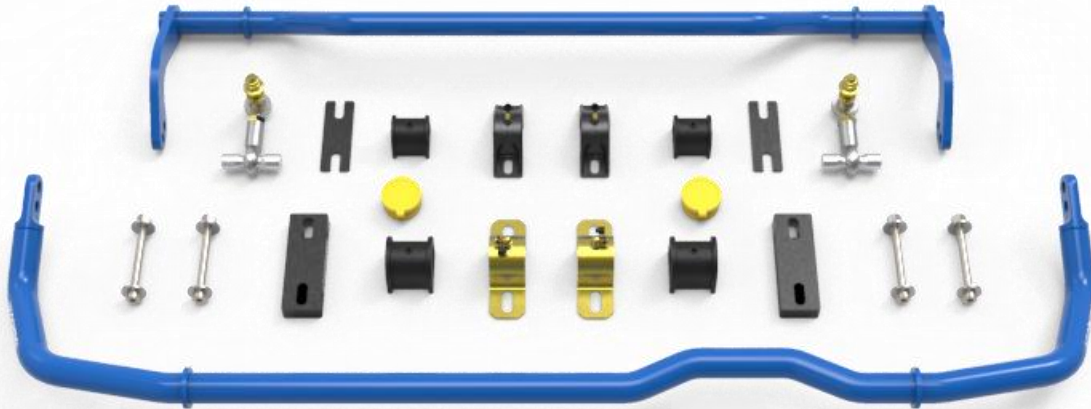

Full Kit Contents	Front & Rear Sway Bar Set	Qty.
00P-OP2567-L	Bar, Front Sway: GTI MK7	1
00P-OP2568-L	Bar, Rear Sway: GTI MK7	1
00P-OC1713-A	Bracket, Slotted Std Bushing (Yellow Zinc)	2
00P-OP2556-B	Bracket, Type 1 S/B (Black Anodize) (Rear)	2
00P-OC1726-B	Bushing, Poly: 1.125"ID, 5343G (Front)	2
00P-OC1727-B	Bushing, Poly: 1" ID 5708.01 (Rear)	2
00P-OC1697-A	Fitting, Grease: 1/4-28 Self Tap 90° (Front)	2
00P-OC1175-A	Fitting, Grease: 1/4-28 Self Tap (Rear)	2
00P-OC1698-A	Cap, Grease Fitting	4
00P-OP2561-B	Spacer, Type 2 Bracket .625" Thick (Front)	2
00P-OP2562-B	Spacer, Type 1 Bracket .125" Thick (Rear)	2
00P-0A1713-A	Kit, Hardware Golf R (Front)	1
00P-OC1714-A	Rod End, 7/16" Male RH Thread	2
00P-OP2610-A	Spacer, End Link .438/M10/.125	4
00P-OC1753-A	Bolt, SHCS, M10-1.5x50mm Clear Zinc	2
00P-OC1728-A	Rod End, 7/16" Female RH Hand	2
81052	Nut, M10-1.5, Flanged Nylock, Class 10	2
00P-OC1716-A	Nut, Jam: 7/16-20 RH Thread	2
00P-OP2569-A	Spacer, OD .625/ID .328/SP .887	4
00P-OC1735-B	Plug, Snap In, .500 ID (Installed on R. Bar)	2
00P-OC1007-A	Packet, Grease: Poly Bushing (0.5 oz)	2
00P-OP2538-W	Decal, Sway Bar: aFe Control 2.8"(Wht)	6

Recommended Tools:

Sockets: 10mm, 13mm, 15mm, 16mm, 18mm, 21mm
Wrenches: 17mm, 18mm
Triple Square: M6, M10

Preferable Equipment:

- 2-Post Lift
- Hydraulic Transmission Jack
- Screw Jack

Front Sway Bar Installation:

- 1F Raise the vehicle with a 2-post lift (preferable), or floor jack. If using a floor jack, place jack stands in the factory designated jack points. You are not required to remove the front wheels for the front installation.

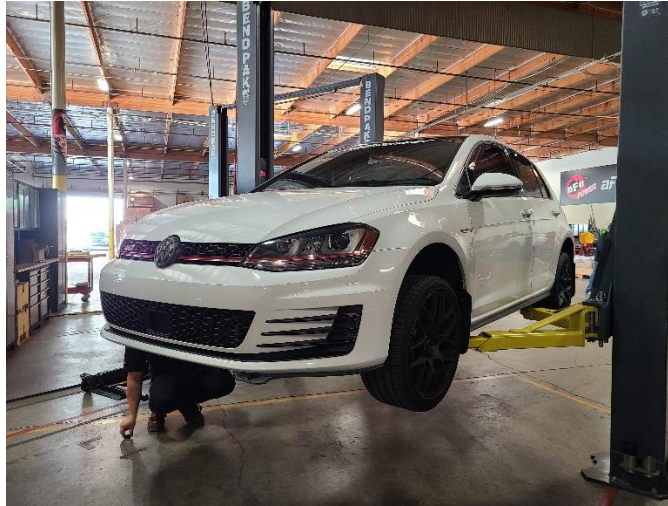

- 2F The front sway bar resides in between the subframe and engine. Dropping the subframe is necessary.

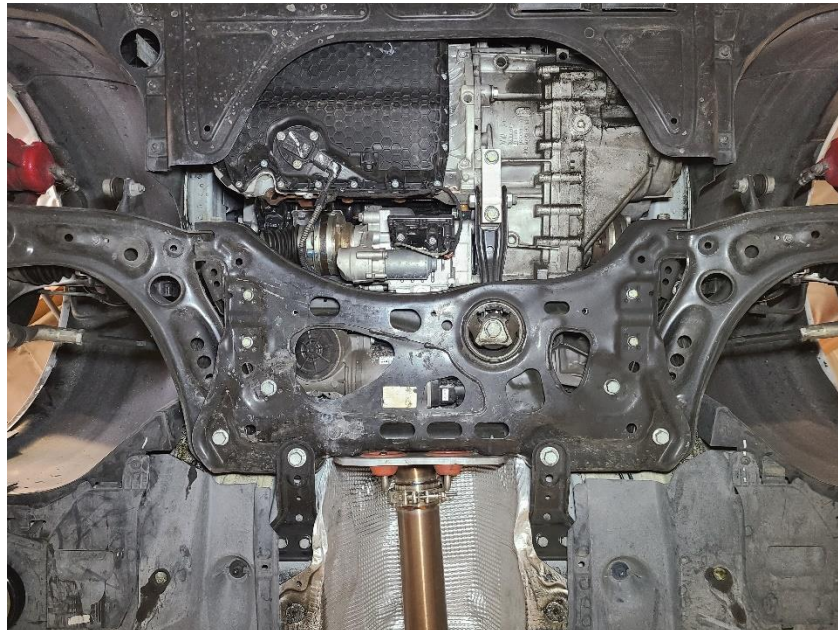

- 3F Disconnect the ride height sensor bracket from the driver side and passenger side lower control arm, using a 10mm socket.



- 4F Disconnect the end links from the stock sway bar using a (18mm wrench) for the nut and (M6 Triple Square socket) for the stud.

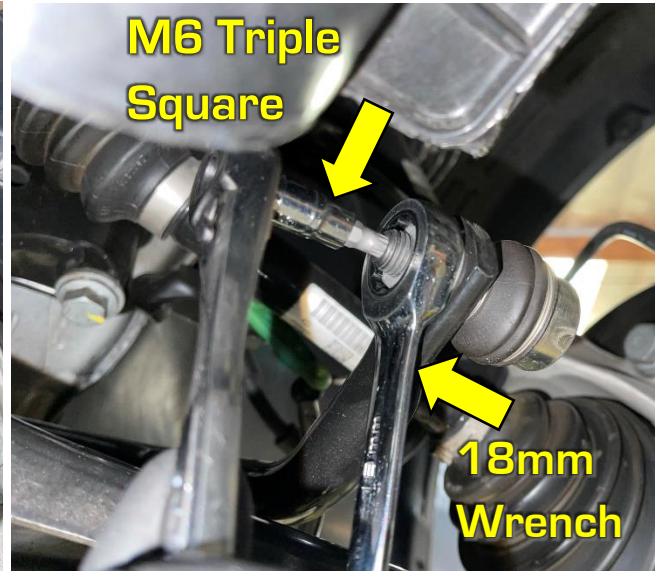
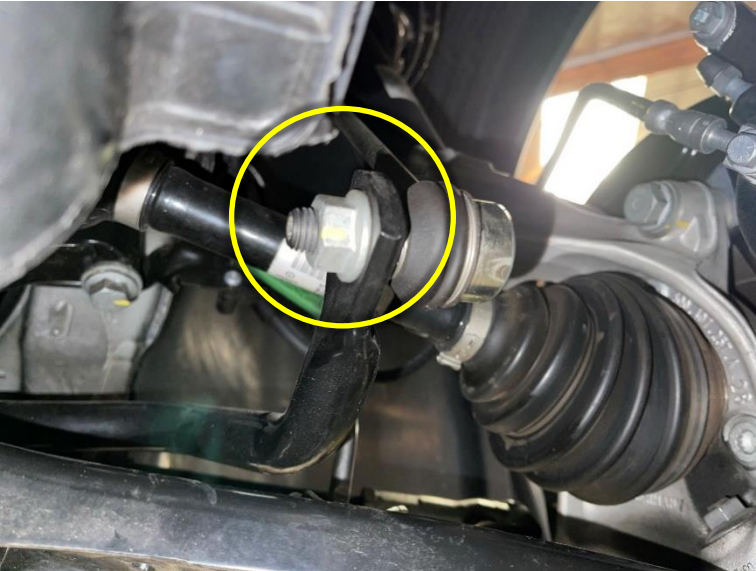

5F Undo the exhaust bracket from the back of the subframe. (13mm socket)



6F Disconnect the engine/trans dog bone mount with a 21mm wrench and socket.

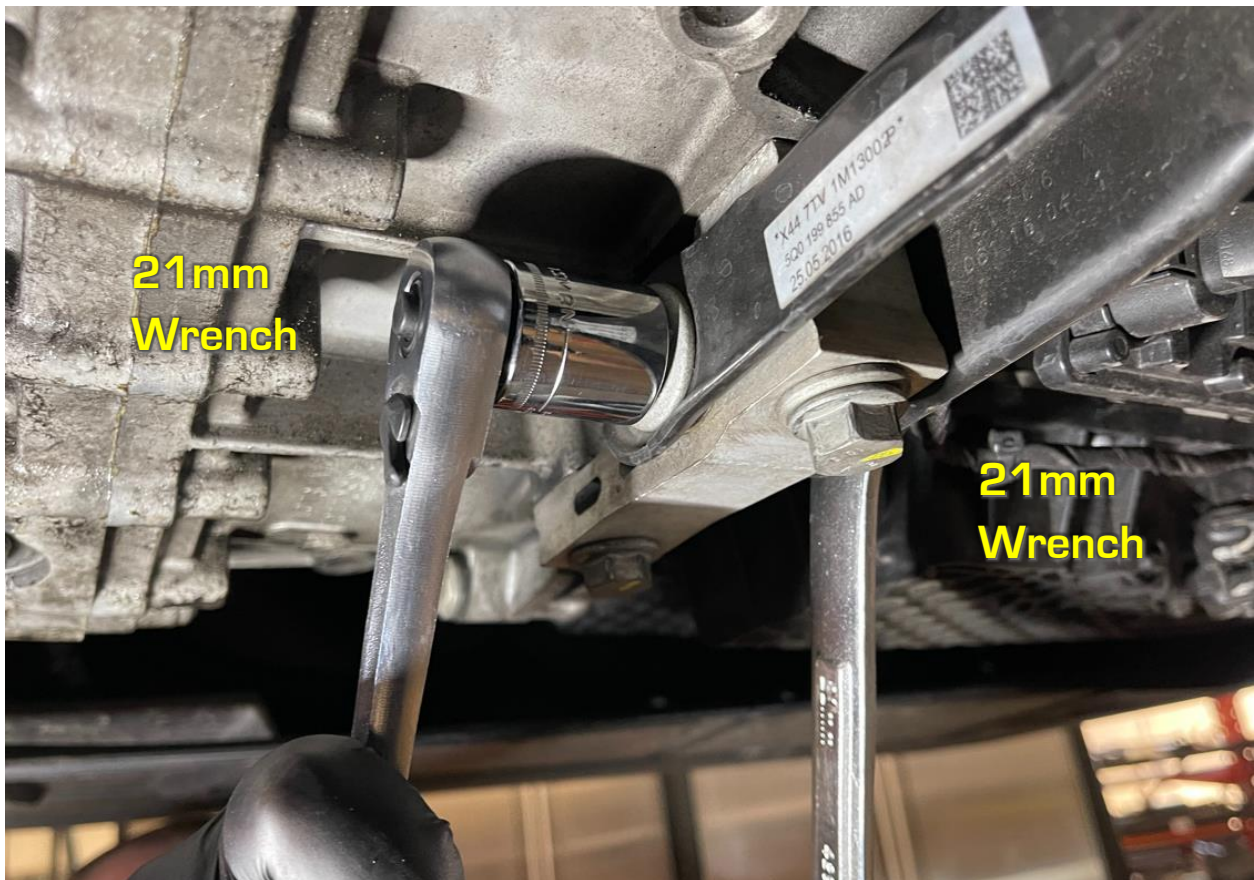

7F Undo the (4) sway bar bushing mounts bolts with a (13mm socket).

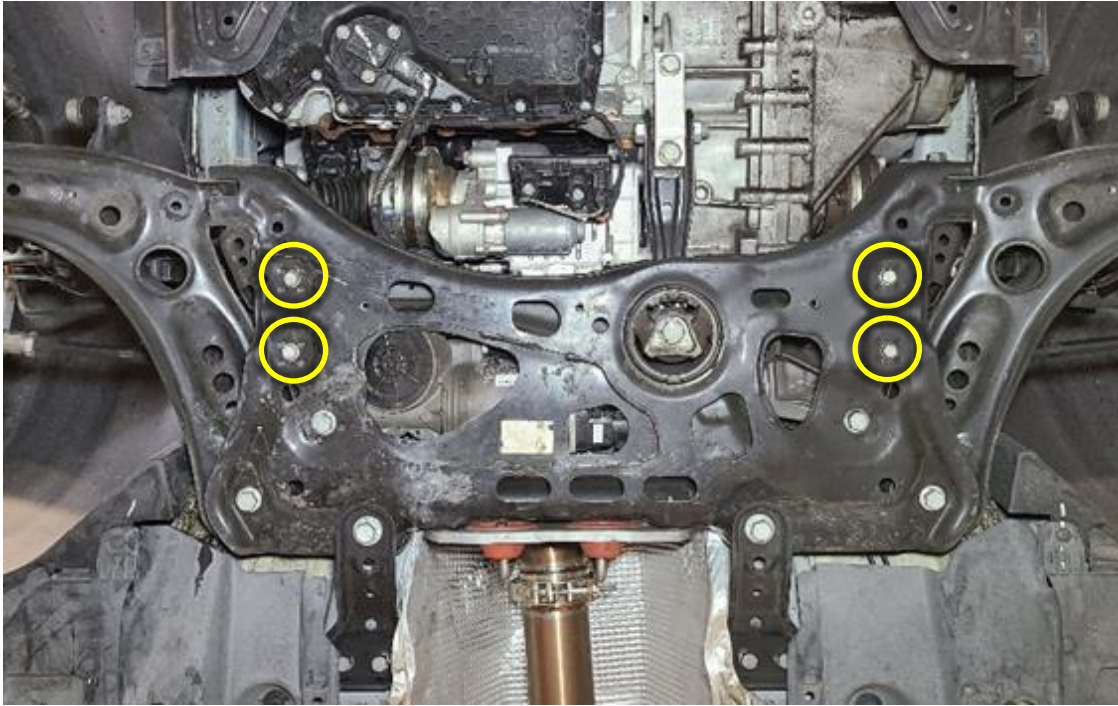

8F Undo the (2) steering rack bolts with a (18mm socket).

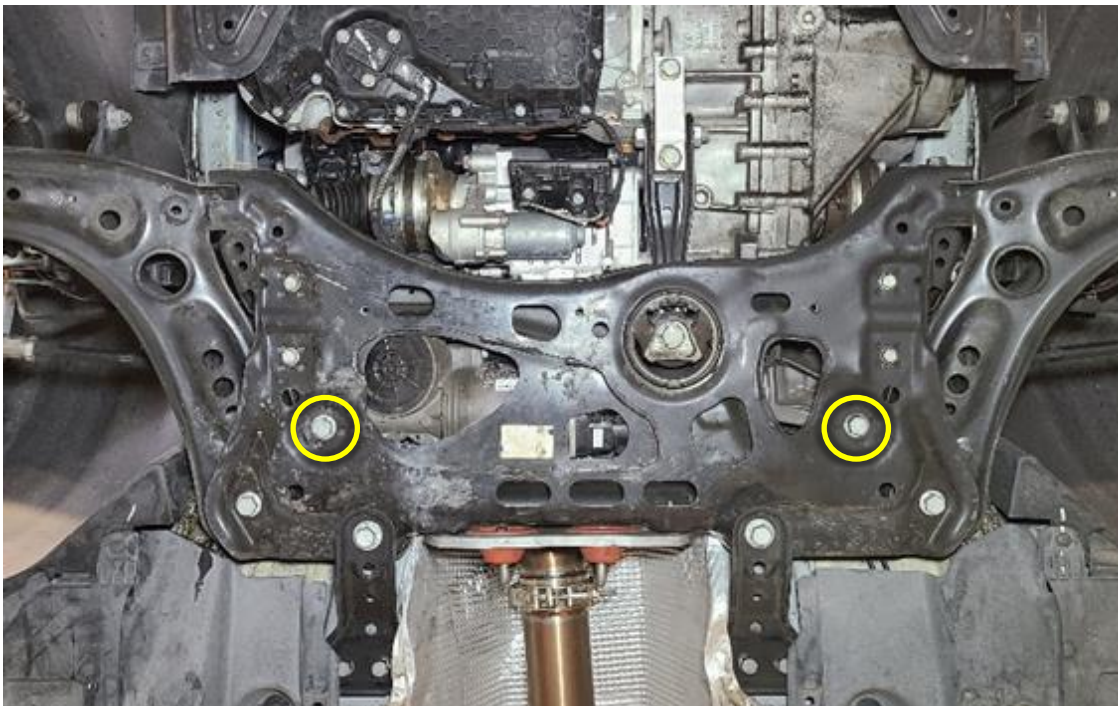

- 9F Unclip the oil sensor connector and clips holding the harness to the pan. Unclip the connector on the transmission distribution module.

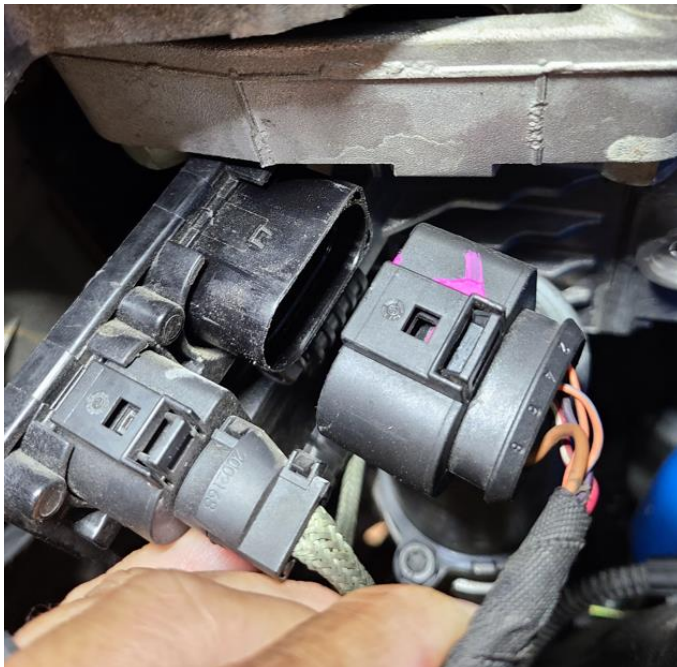

Pry the push-clip to release sensor line from the subframe

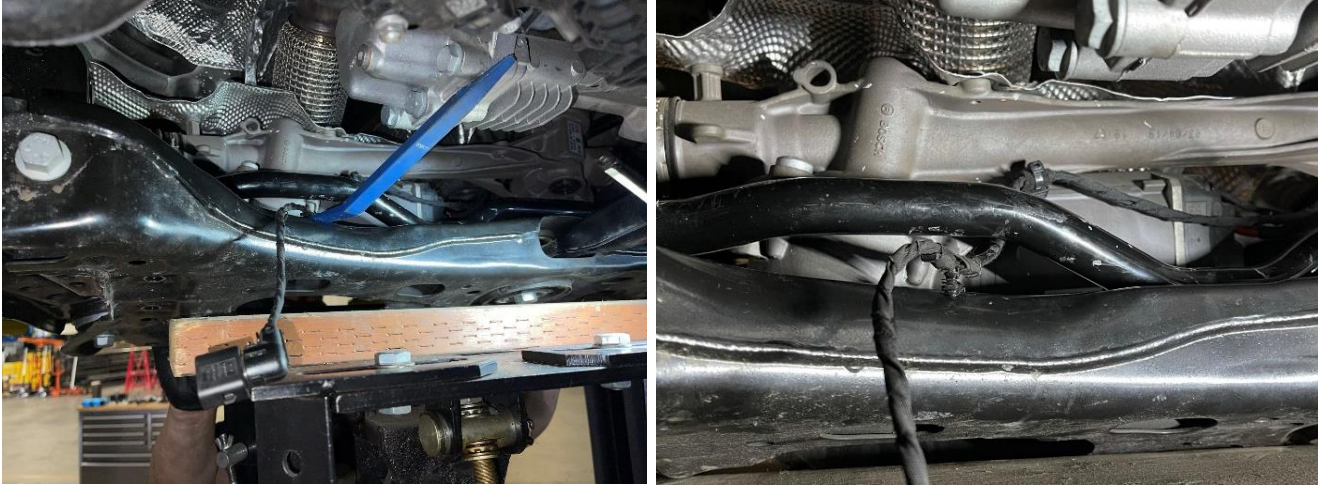

Route this wire harness up and around the factory sway bar so it rests on top of the sway bar. This will keep the wire harness out of harms way when the sway bar is removed towards the rear of the vehicle.

10F Unclip the ride height sensor connector on both driver and passenger side.

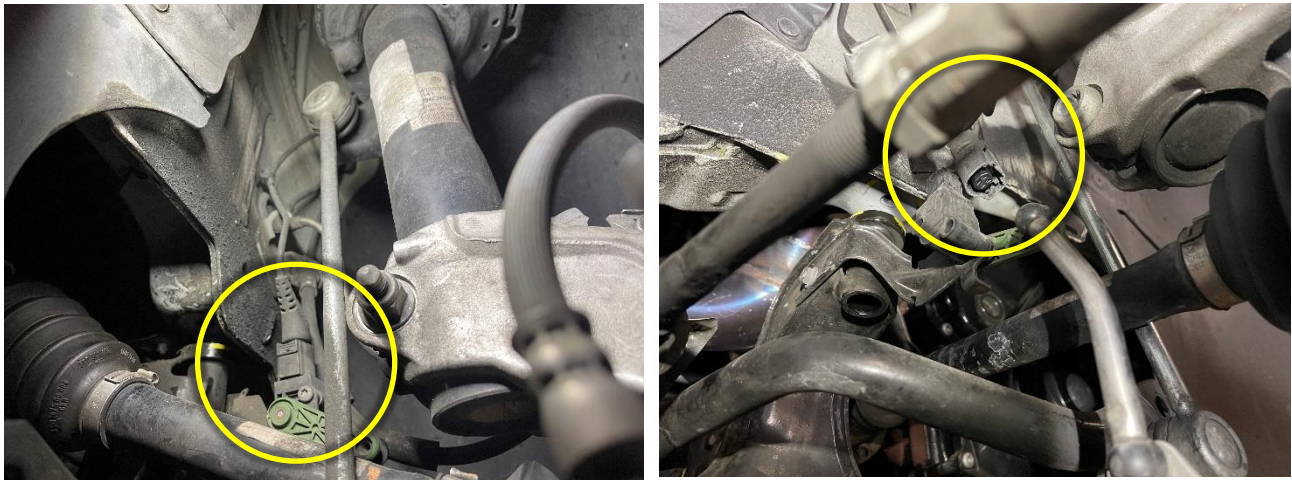

11F Support the subframe with a transmission jack.



12F The subframe should now be held up by only the main bolts and brackets.

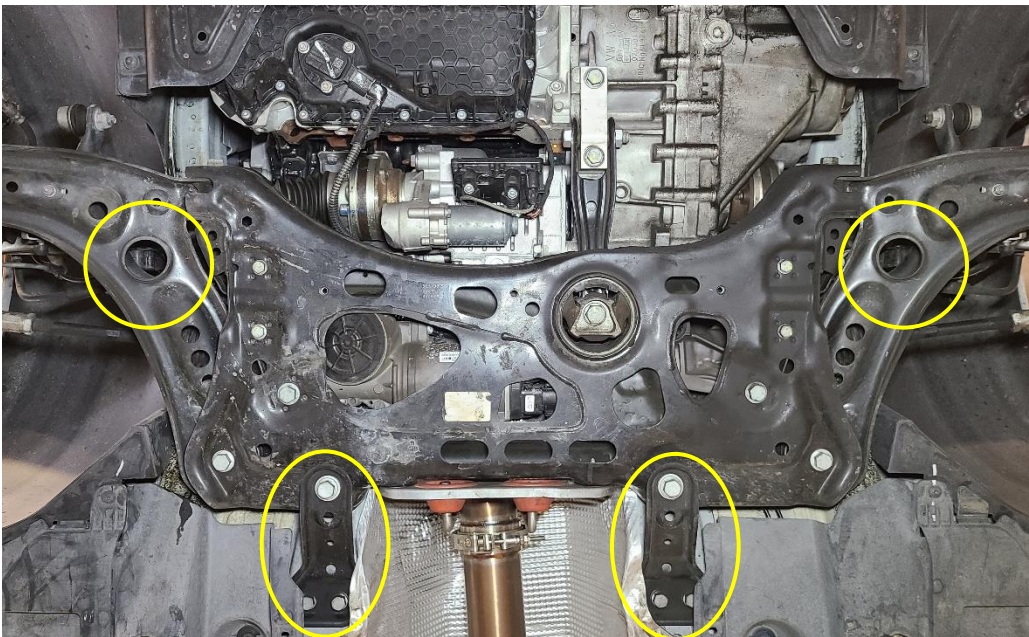

Undo the rear mount brackets with a (16mm and 18mm sockets).

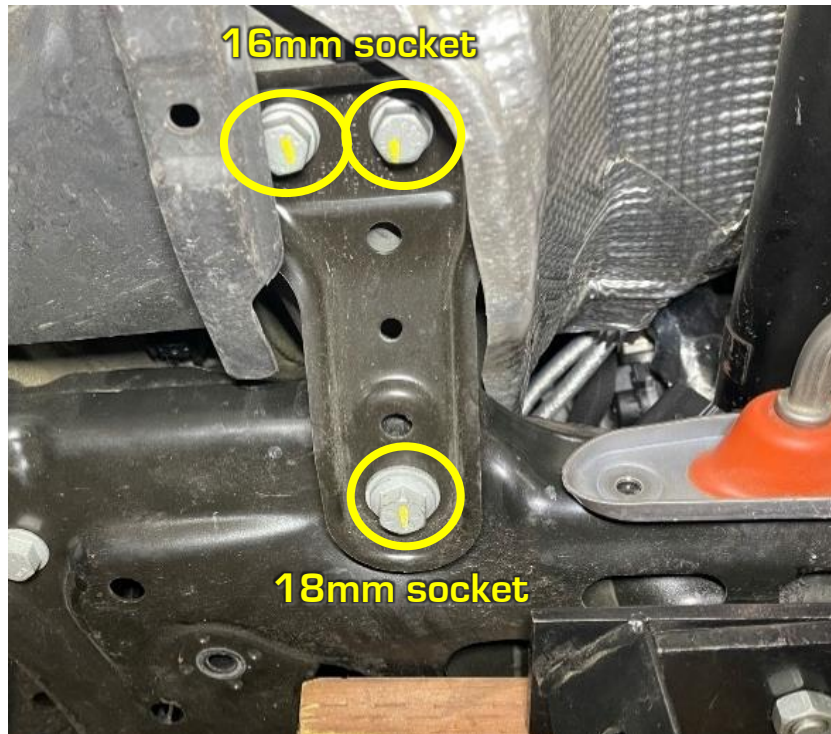

13F Undo the forward subframe bolts with a (18mm socket).



- 14F Lower the sub frame just enough so the sway bar can be removed towards the rear of the car. You will need to lift the steering rack and sneak the sway bar under and out the back.



- 15F As you lower the subframe you will gain access to this line clip. Unclip this attachment point on driver side near the forward subframe mount.



- 16F Lay out the factory sway bar with the aFe Control sway bar to match the orientation.

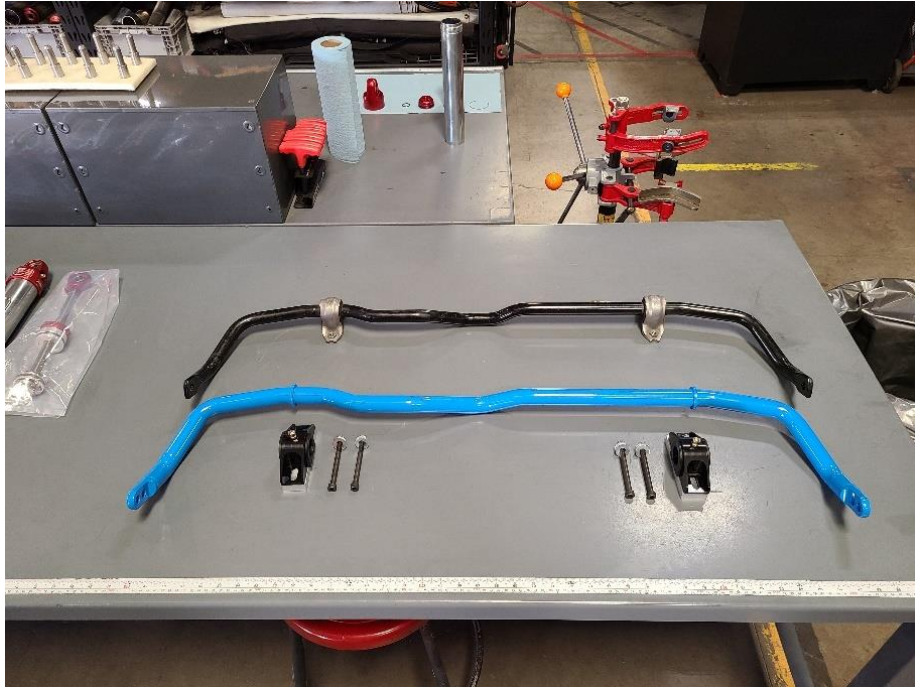

- 17F Install the front aFe Control sway bar in the same manner as factory removal. We suggest leaving the sway bar in the poly bag when feeding it into the car. This will keep it safe from scratches. (remove the poly bag once bar is in place)





18F Grease the front bushings (5343) with the supplied silicone lube. Install bushing onto the sway bar. The bushings should be positioned just inside of the centering rings.



19F Slide the aFe Control bushing bracket onto the bushings with the grease fitting facing out. The thick black aluminum spacer goes between the bushing and the subframe. Use the supplied hardware kit (p/n 00P-0A1713-A) to secure the brackets to the subframe. See diagram below:

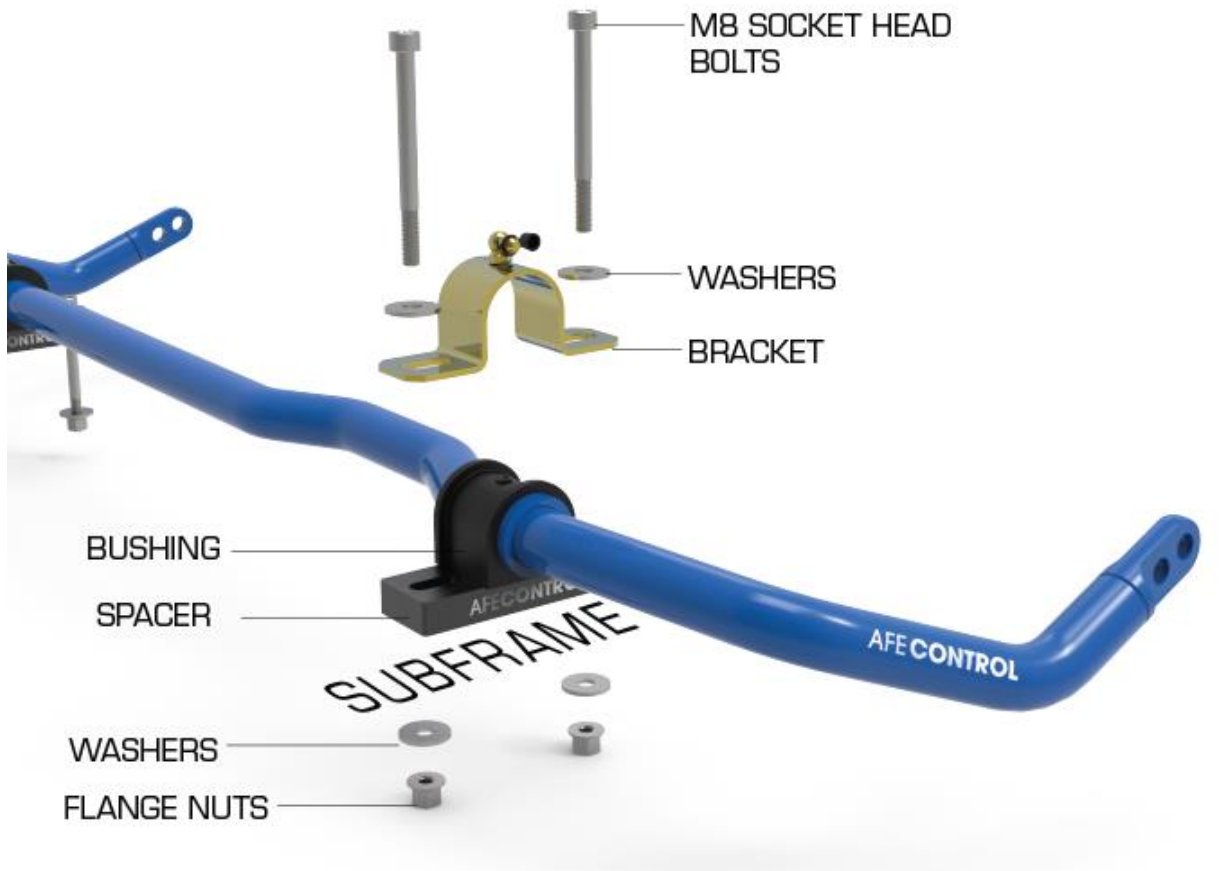

The bushing brackets are slotted to allow for positioning the bar. Slide the sway bar forward making sure the bar has clearance between the steering rack and the subframe. Tighten the hardware to 35 ft·lbs.



- 20F Perform steps 1F-15F in reverse order. When attaching the end links to the sway bar you have 2 settings: Medium and Stiff. The hole closest to the end is the Medium setting. Stiff Setting shown. (Tip: Apply medium thread locking compound on the end link stud to ensure the nut does not come loose over time)



You are finished with the front installation.

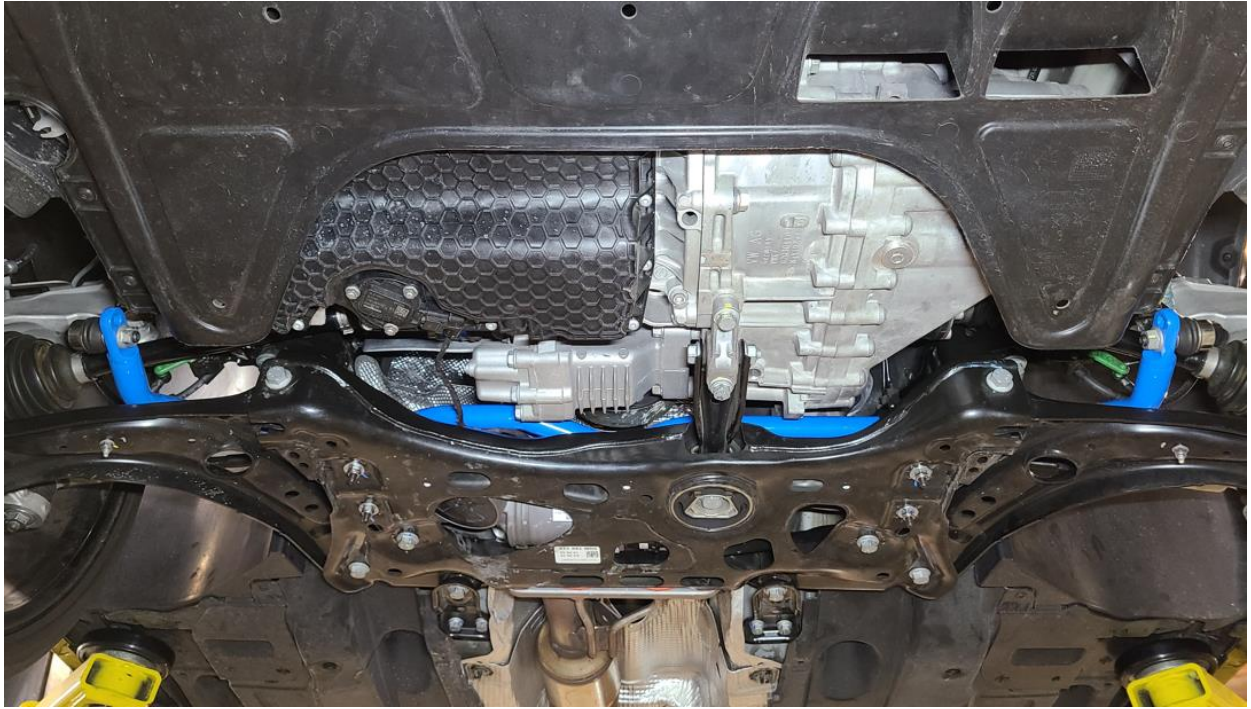

Rear Sway Bar Installation:

- 1R Raise the vehicle with a 2-post lift (preferable), or floor jack. If using a floor jack, place jack stands in all four of the factory designated jack points.

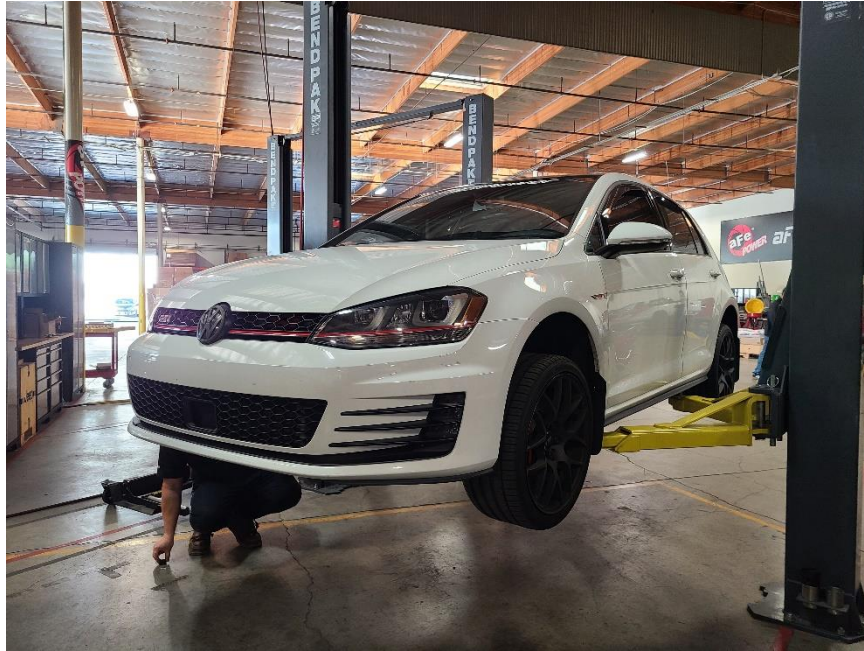

- 2R Disconnect the end links from the stock lower control arms using a (13mm socket) for the nut and (13mm wrench) for the stud.

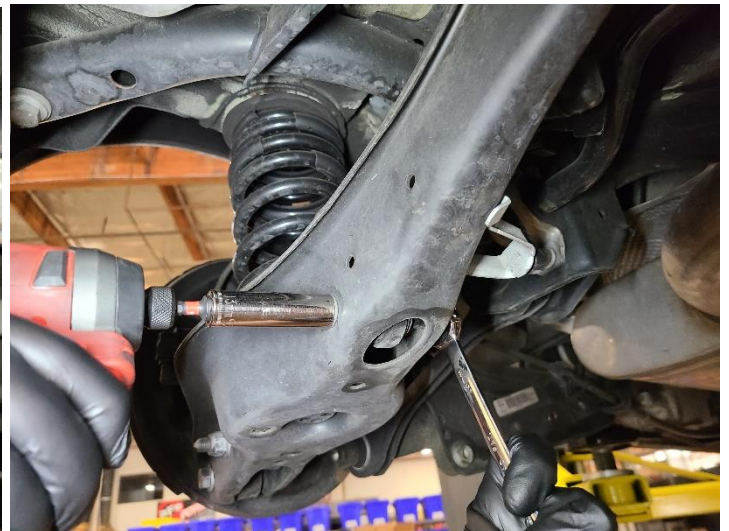
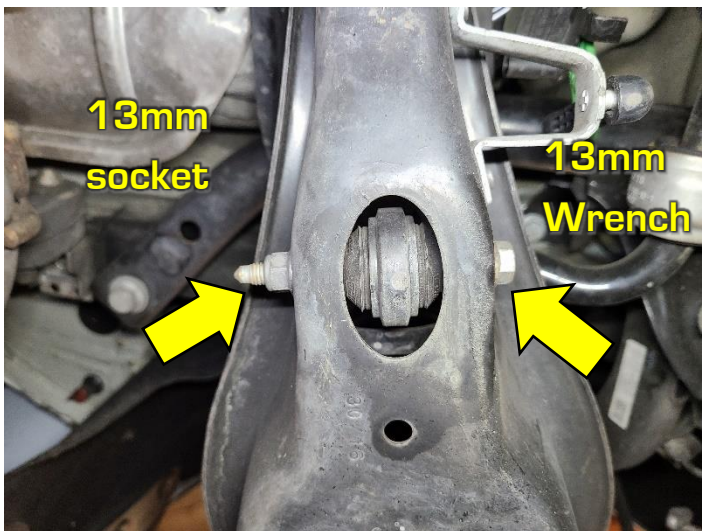

3R Remove the bushing brackets with a (M10 Triple Square).



4R Support the exhaust with a screw jack.

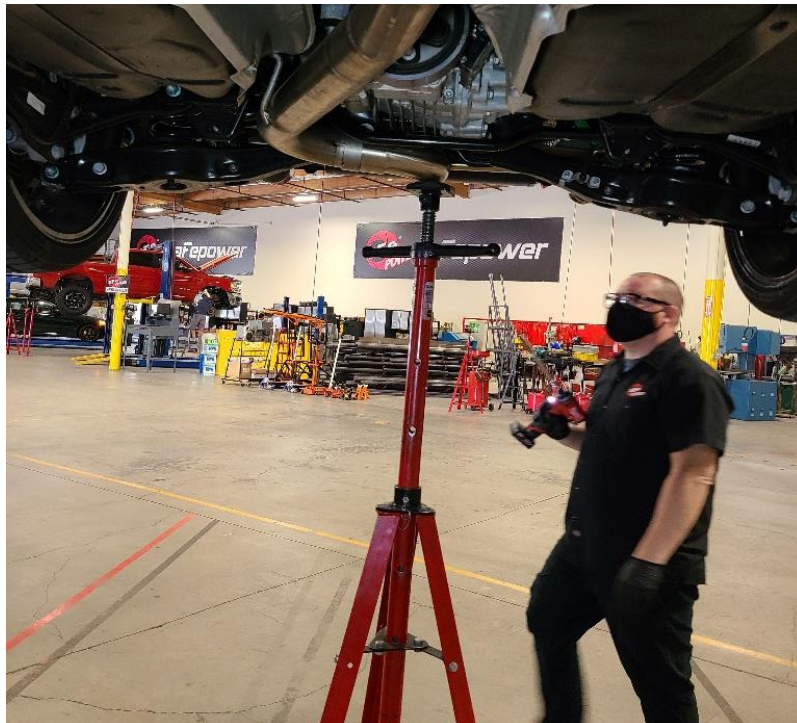

5R Unbolt the center brace and exhaust hanger with a (13mm socket).

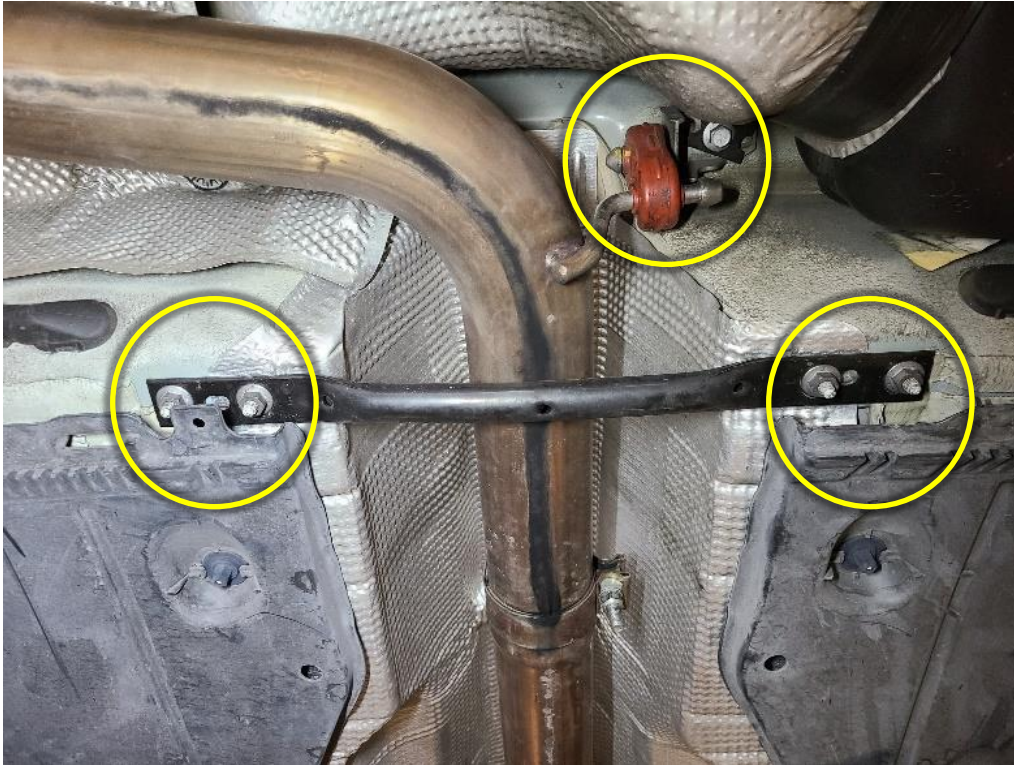

6R Remove exhaust hanger bolt from both sides with a (13mm socket).

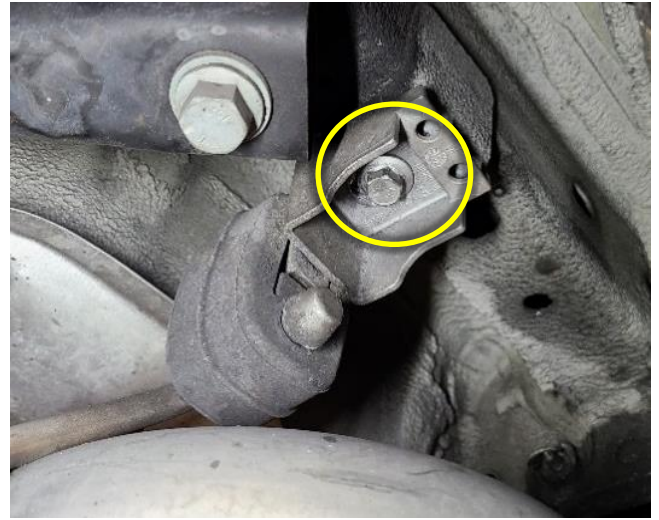

7R Lower the exhaust slightly and remove the factory sway bar from the vehicle. Note the orientation of the sway bar when removing. (i.e. observe which is the top of the sway bar and how the ends are pointing.)



- 8R Lay out the factory sway bar with the aFe Control sway bar to match the orientation.



- 9R Install the rear aFe Control sway bar in the same manner as factory removal. We suggest leaving the sway bar in the poly bag when feeding it into the car. This will keep it safe from scratches. (remove poly bag once bar is in place)

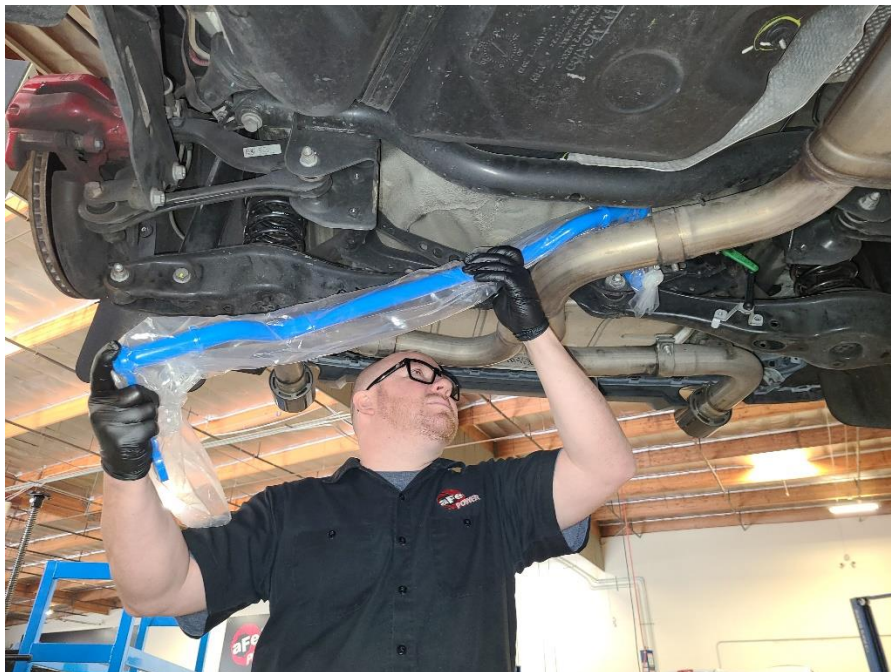

10R Grease the rear bushings with the supplied silicone lube.



11R Install the bushing onto the sway bar. The bushings should be positioned just outside of the centering rings. Slide the aFe Control bushing bracket onto the bushing. The thin black aluminum spacer goes between the bushing and the subframe. Fully tighten this hardware to 40 ft-lbs.

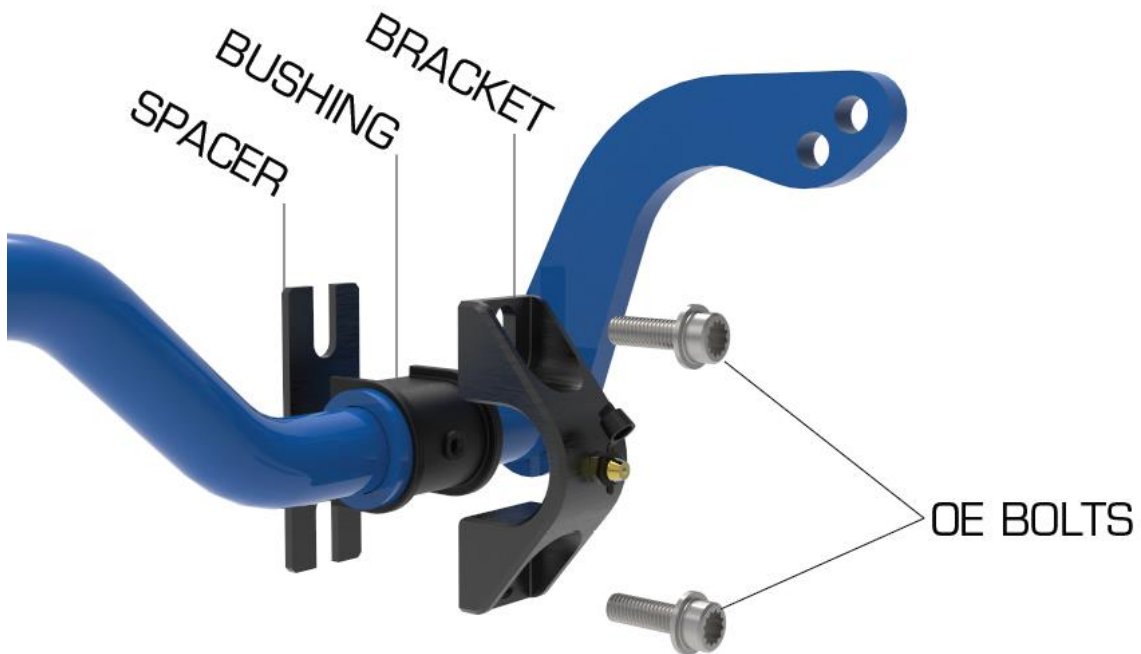

12R Make sure the provided end link is correctly assembled and adjusted to the shortest length. Install the provided end link onto the sway bar using a (8mm allen and a 15mm socket). Tighten to **40ft lbs**. Do not use an impact gun or over tighten.

Torque to 40 ft·lbs

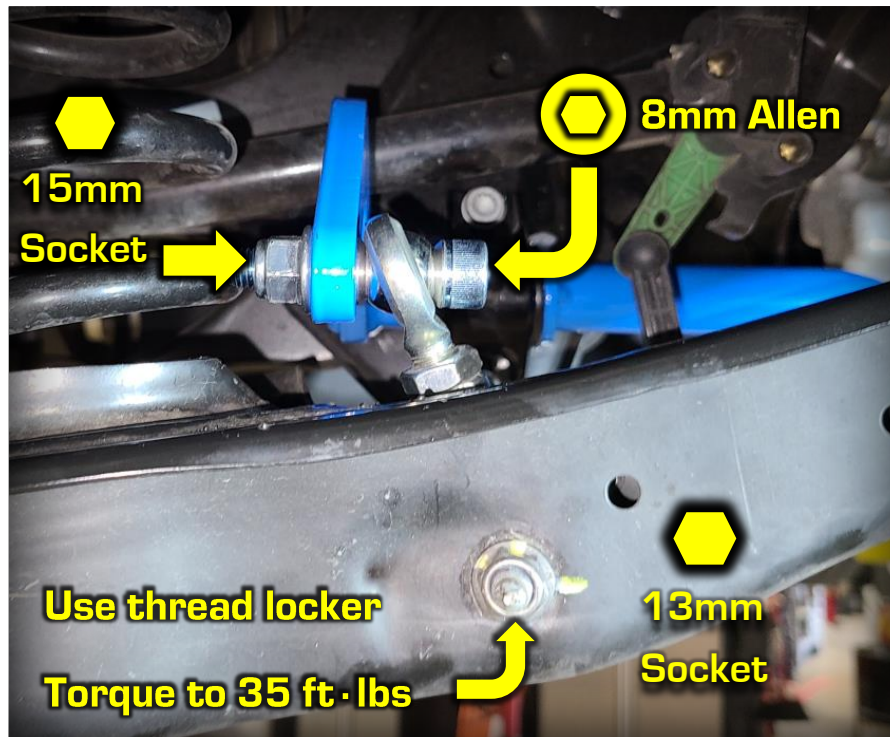
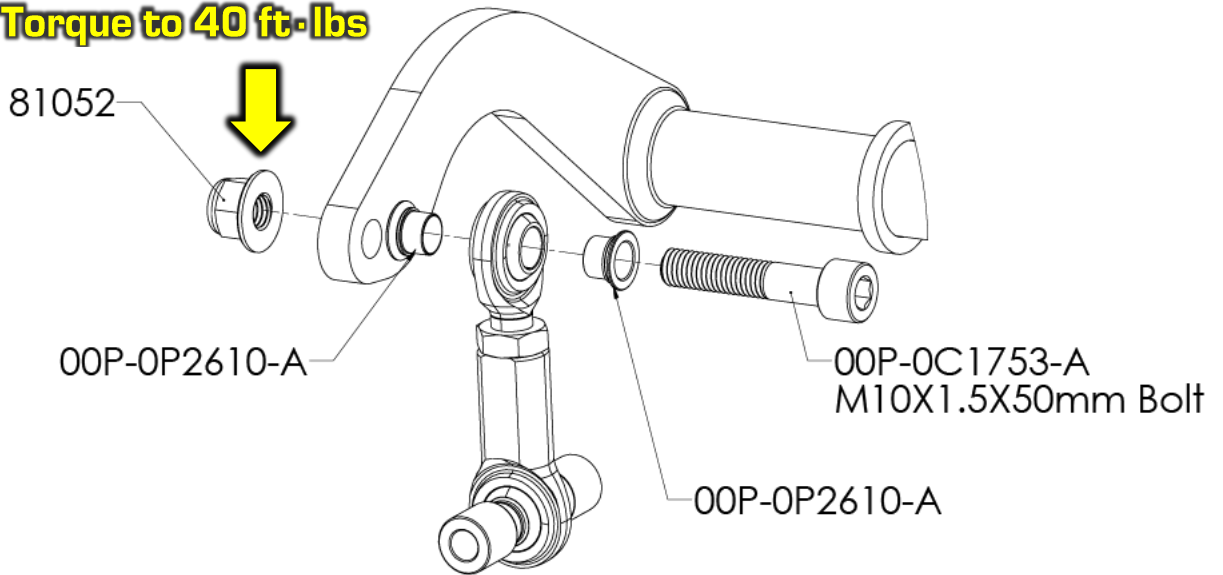

(Picture above shows normal end link angle at full droop)

13R Perform steps 1R-6R in reverse order. You are finished with the rear installation.

Stiffness Chart and Tuning:

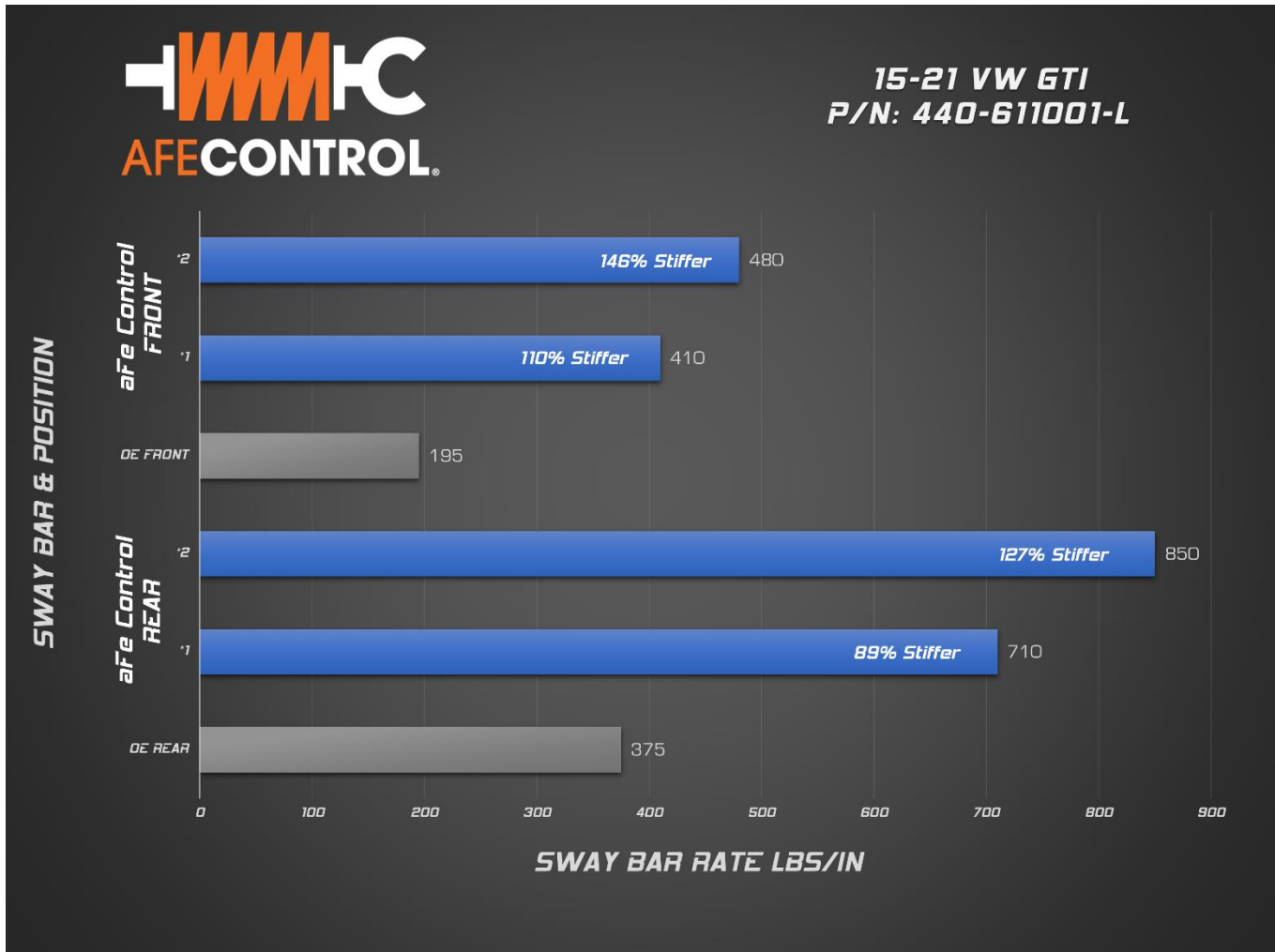

Stiffer roll resistance will demand more from the tires. When the tire's grip is overloaded, they will begin to slip. Manipulating when the front or rear tires slip can make the vehicle understeer, oversteer, or handle neutral. So, think of it as the higher the stiffness, the earlier the slip. If the front slips first, you will have understeer. If the rear slips first, you will have oversteer. If both front and rear slip near the same time, you will have neutral handling.

(Note: Handling characteristics highly depend on wheel alignment and how much grip your tires have)

Suggested Initial Settings:

Front: Position #2 Full Stiff

Rear: Position #1 Full Soft