

advanced FLOW engineering

Momentum HD Cold Air Intake System

Instruction Manual P/N: 50-70137D / 50-70137T

Make: **RAM**

Model: **2500**

Year: **2025-2026**

Engine: **L6-6.7L(td) Cummins**

Make: **RAM**

Model: **3500**

Year: **2025-2026**

Engine: **L6-6.7L(td) Cummins**



- Please read the entire instruction manual before proceeding.
- Ensure all components listed are present.
- For technical support please call at 951-493-7185.
- Ensure you have all necessary tools before proceeding.
- Do not attempt to work on your vehicle when the engine is hot.
- Retain factory parts for future use.

Label	Qty.	Description	Part Number
A	1	Air Filter (Pro DRY S) for 50-70137D	21-91147
A	1	Air Filter (Pro 10R) for 50-70137T	20-91147
B	1	Air Intake Tube	05-5070137B1
C	1	Housing	05-5070137B2
D	1	Coupler, Silicone Elbow Reducer	05-01812
E	1	Cap, for housing auxiliary inlet	05-01769
F	1	T-bolt Clamp (8-5/16" - 8-5/8")	03-50267
G	1	Worm Clamp, 064 (3-9/16" - 4-1/2")	03-50006
H	1	Worm Clamp, 072 (4-1/16" - 5")	03-50010
J	1	Screw, Torx: M4 x 16mm	03-50489

Installation will require the following tools:

8mm nut driver or socket, 10mm socket, 11mm socket and ratchet, 6" extension, Clip removal tool, T20 torx bit, pliers

Warranty information available at <https://afepower.com/warranty>

Emissions Disclaimer:

This product is not currently CARB exempt and is not available for purchase in California or for use on any vehicle registered with the California Department of Motor Vehicles.

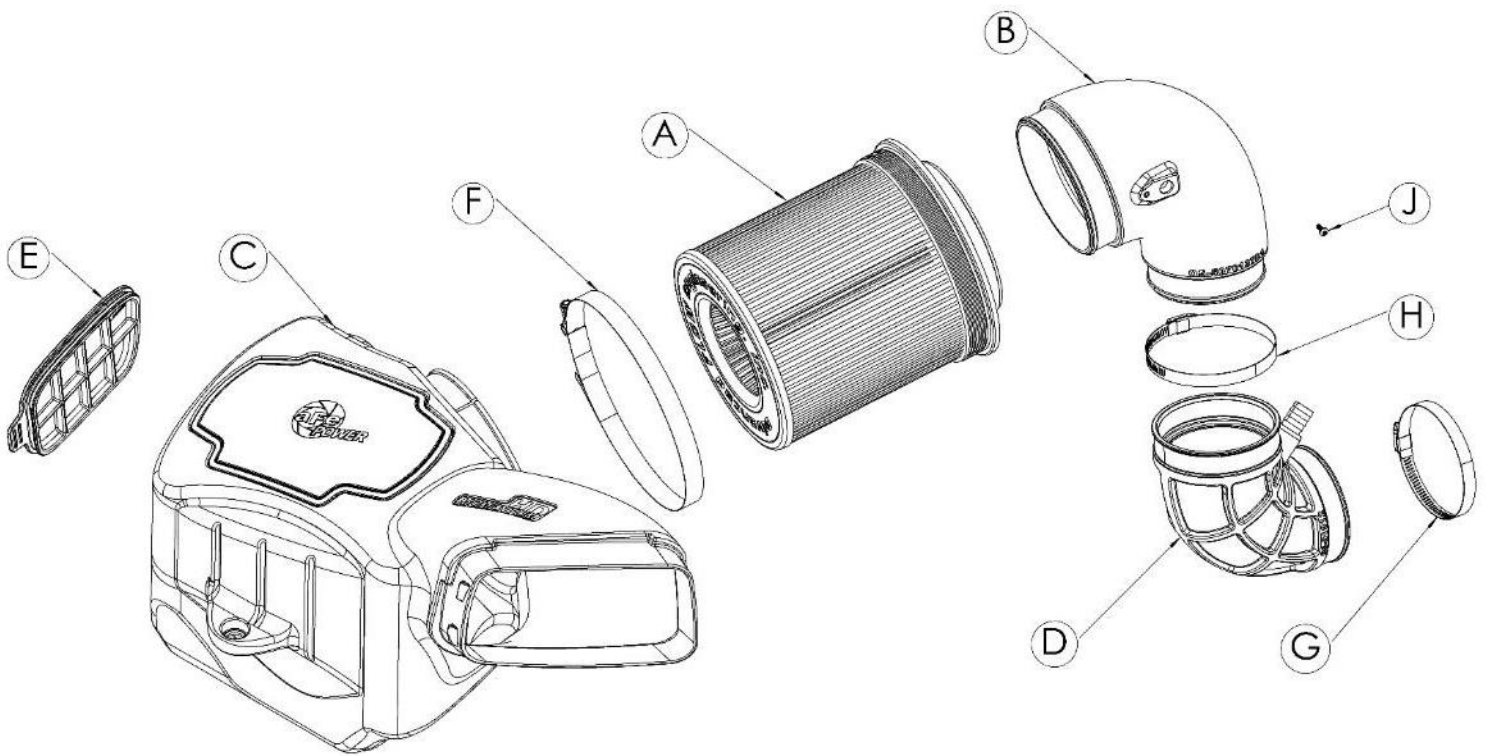



Figure A

Refer to Figure A for Step 1

Step 1: Using a trim clip pry tool, disengage and remove the fourteen (14) factory retaining clips securing the factory trim panel. Carefully separate and remove the trim panel to gain access to the scoop assembly.

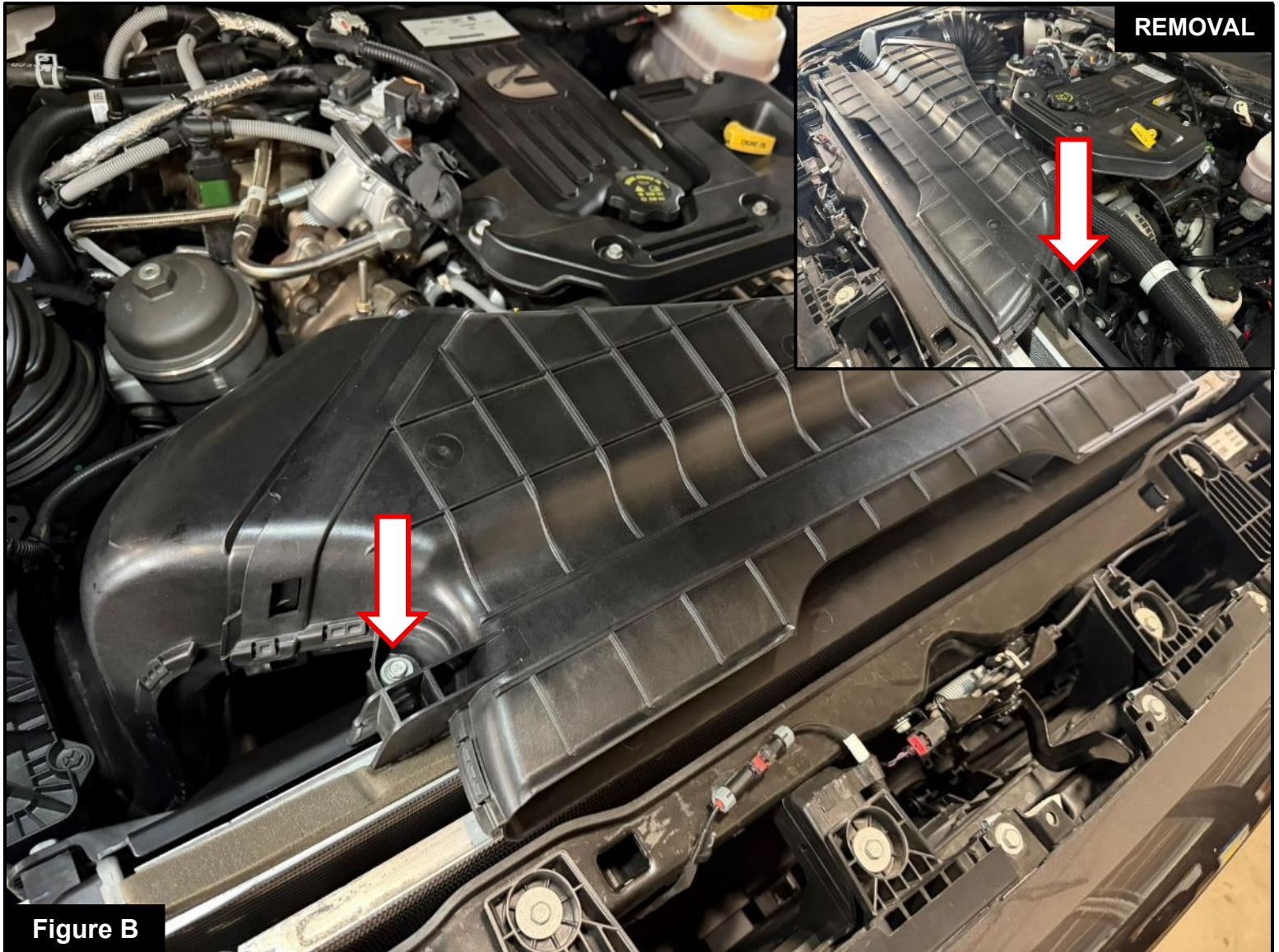
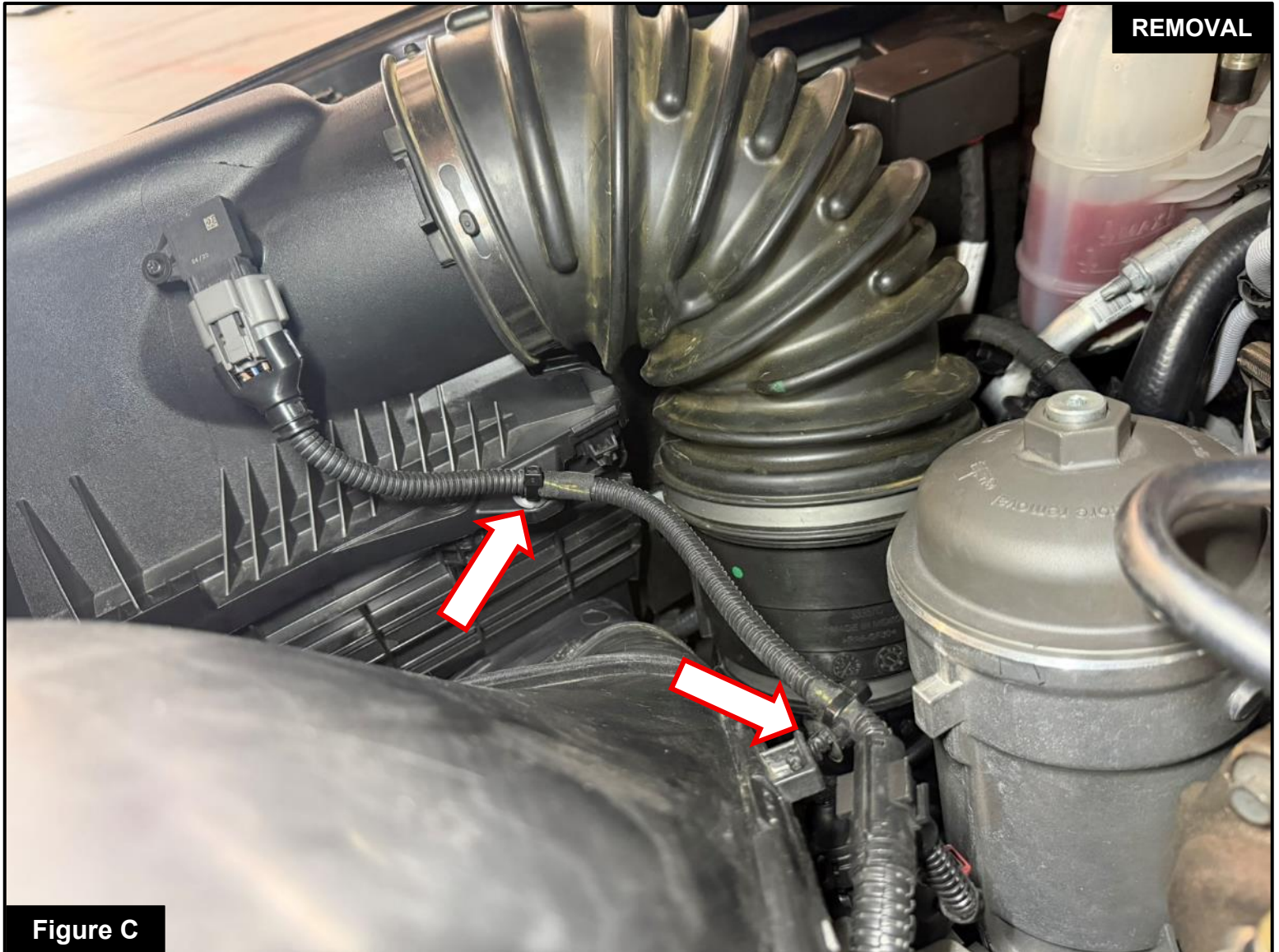

Figure B

Refer to Figure B for Steps 2-3

Step 2: Using a 10 mm socket or nut driver, remove the two (2) screws securing the scoop assembly to the vehicle. Those screws will be reused to install the factory scoop assembly back on.

Step 3: Using a pry tool, carefully disengage the retaining tabs on both sides of the scoop to release it from the factory airbox scoop inlet.



Refer to Figure C for Step 4

Step 4: Unclip and detach the air intake harness from the factory airbox and air scoop inlet.



Figure D

Refer to Figure D for Steps 5-6

Step 5: Disconnect the air intake temperature (IAT) sensor electrical connector.

Step 6: Loosen the hose clamp securing the factory intake tube to the airbox. Remove the airbox out of the vehicle by firmly pulling on it.

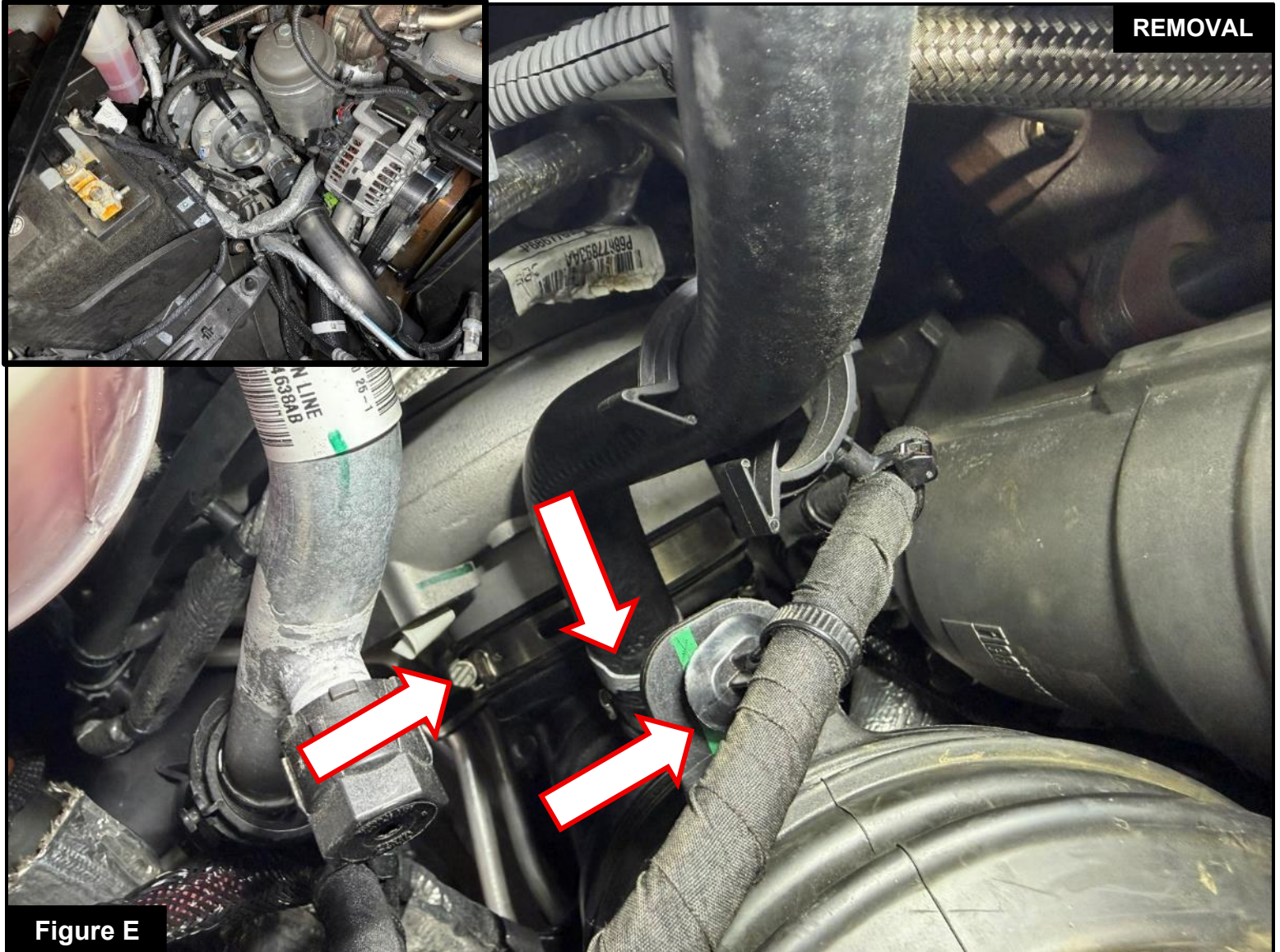

Figure E

Refer to Figure E for Steps 7-9

Step 7: Unclip and remove the wiring harness secured to the factory intake tube.

Step 8: Using pliers, compress and slide the spring clamp out, then disconnect the crankcase hose from the intake tube. Keep the spring clamp on the hose as it will be reused to connect to the aFe POWER Coupler.

Step 9: Loosen the clamp from the turbo using a 8mm socket with extension and remove the factory intake tube.



Figure F

Refer to Figure F for Step 10

Step 10: Remove the three (3) grommets from the factory airbox and transfer them to the Momentum HD housing.

**Figure G****Refer to Figure G for Step 11**

Step 11: Install the aFe POWER air filter into the Momentum HD housing, ensuring it is fully seated and properly aligned. Then slide on the T-bolt clamp onto the housing and onto the filter flange.



Figure H

Refer to Figure H for Step 12

Step 12: The kit includes an optional plug to close off the auxiliary air inlet. If desired, Install the aFe POWER plug onto the housing:

- Without the plug installed, the aFe POWER intake will capture the maximum amount of air available. More airflow can lead to increased power, but some of this air may come from inside the engine compartment and could be warmer, potentially affecting vehicle performance.
- Installing the plug on the housing will block out hot engine air, ensuring that only the coolest air is directed into the engine. This will also help reduce air intake noise.



Figure J

Refer to Figure J for Step 13

Step 13: Using a T20 Torx driver, remove the air intake temperature (IAT) sensor from the factory intake tube and transfer it to the aFe POWER intake tube. Using the provided screw, secure the sensor to the aFe POWER intake tube. Ensure the sensor is fully seated and properly oriented. Tighten the screw until snug. Do not overtighten.

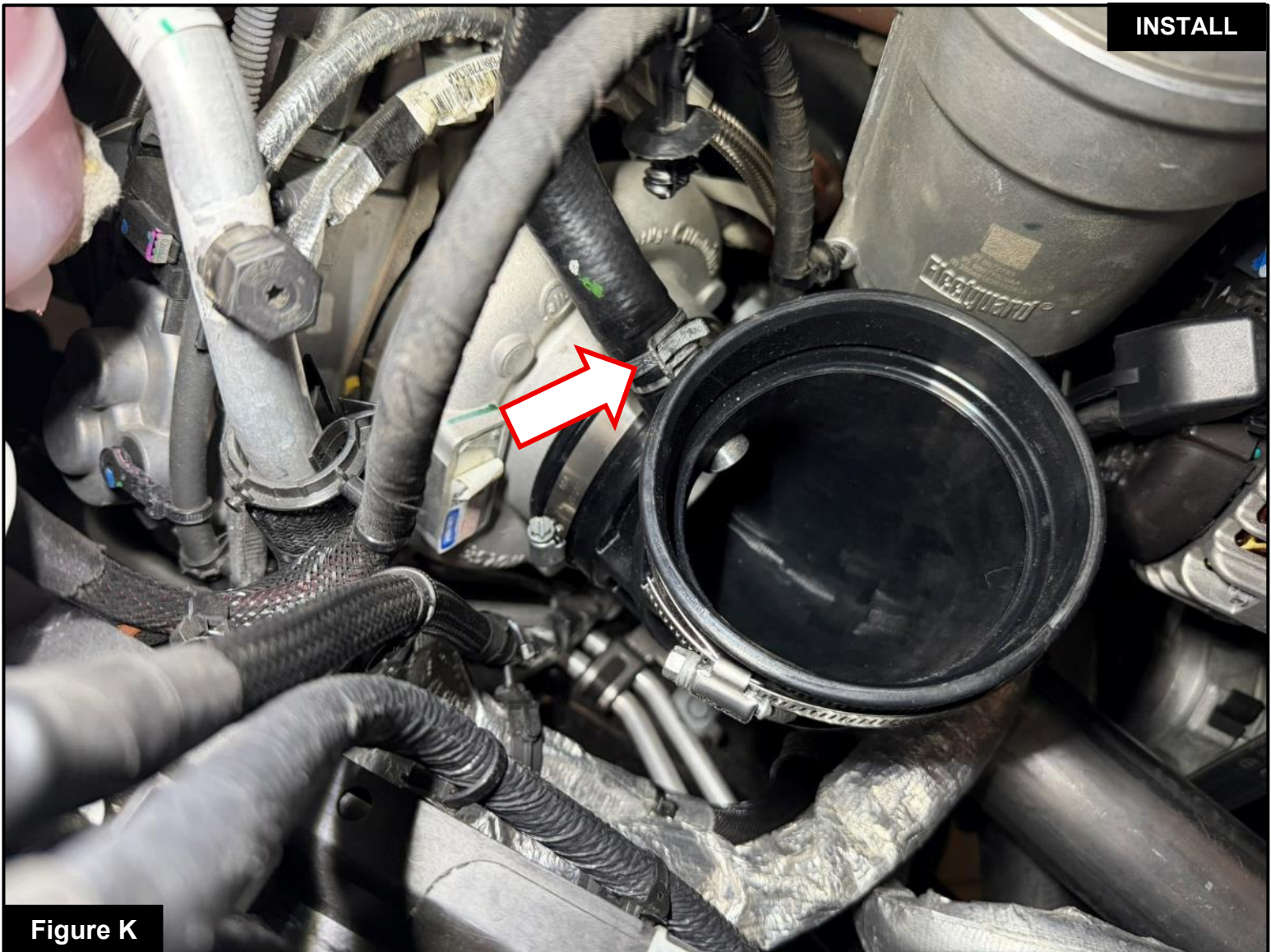

Refer to Figure K for Steps 14-15

Step 14: Pre-install the supplied worm gear clamps onto the coupler, placing the #64 clamp on the turbo side and the #72 clamp on the intake tube side. Once the clamps are in position, install the coupler onto the turbo. Do not tighten the clamps at this time.

Step 15: Reconnect the resonator hose and secure it using the factory spring clamp, ensuring the clamp is fully seated.



Figure M

Refer to Figure M for Step 16

Step 16: Install the aFe POWER housing assembly into the vehicle, aligning the grommets on the housing with the factory mounting pegs. Press down firmly to sit the housing securely.

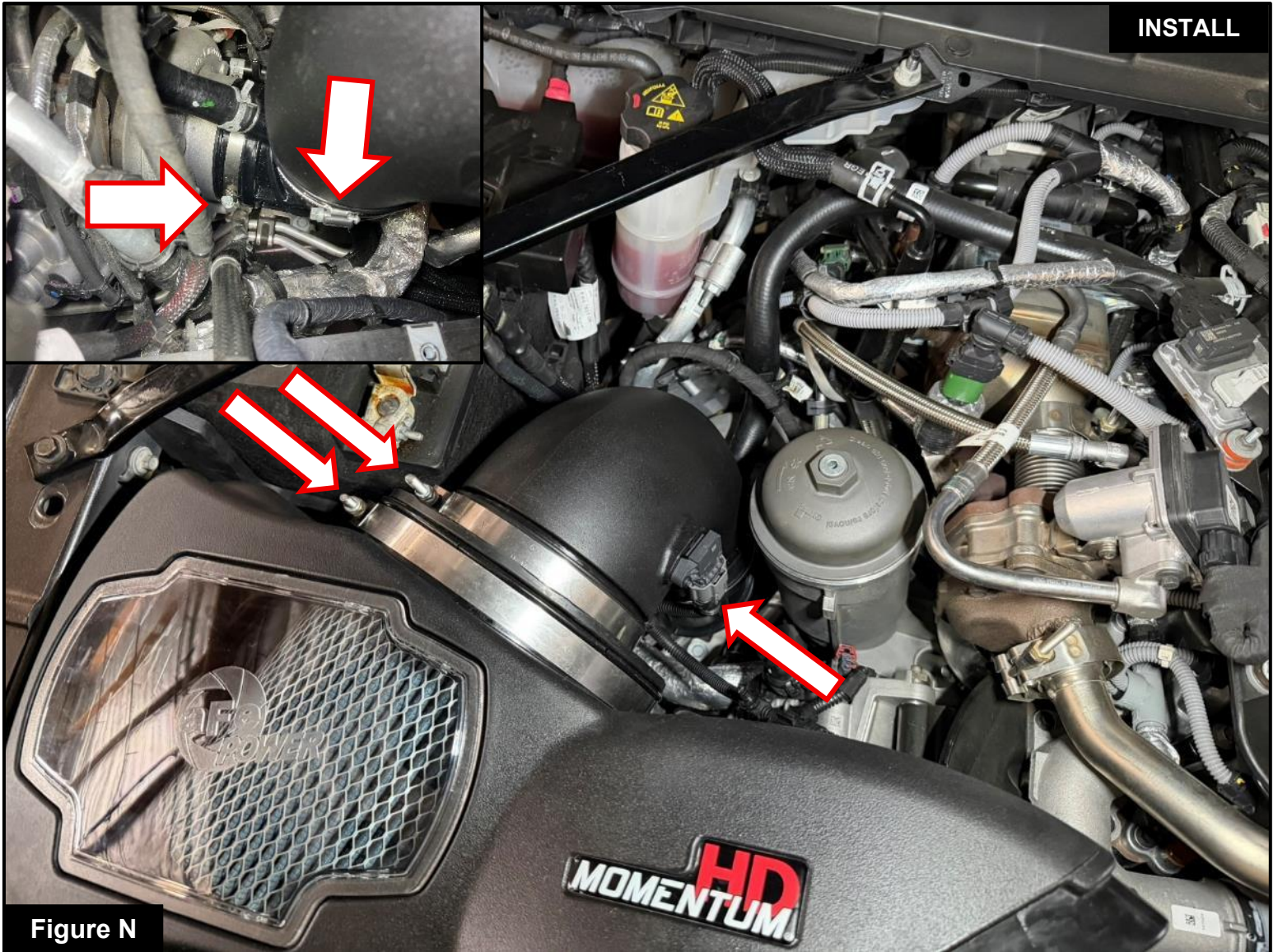

Figure N

Refer to Figure N for Steps 17-19

Step 17: Install the aFe POWER intake tube into the coupler first, then slide the tube into the air filter.

Step 18: Make sure the coupler, tube and filter are aligned correctly, then using an 11 mm socket or nut driver, tighten the clamps on the housing and on the air filter. Using an 8 mm socket or nut driver, tighten the turbo and intake tube clamps.

Step 19: Reconnect the air intake temperature (IAT) sensor electrical connector, ensuring it is fully engaged and locked in place.



Refer to Figure P for Step 20

Step 20: Reinstall the factory scoop over the Momentum HD housing. Use the screws removed from **Step 2** to secure the scoop.



Figure Q

Refer to Figure Q for Step 21

Step 21: Reinstall the factory trim and clips.

Your installation is now complete. Thank you for choosing aFe POWER!

NOTE: Check to ensure that all screws, clamps, and connectors are secure after 100-200 miles



PAGE LEFT BLANK INTENTIONALLY



PAGE LEFT BLANK INTENTIONALLY



advanced FLOW engineering, inc.

Corona, CA 92879

<https://afepower.com/contact>