

## 2021-2025 Polaris Ranger Frame Stiffener

**Thank you for choosing Rough Country for all your vehicle needs.**

Please read instructions before beginning installation. Check the kit hardware against the kit contents shown below. Be sure you have all needed parts and know where they go.

If question exist, please call us @1-800-222-7023. We will be happy to answer any questions concerning this product.

Check all fasteners for proper torque. Check to ensure for adequate clearance between all components.

Check and retighten wheels at 50 miles and again at 500 miles. Periodically check all hardware for tightness.

### KIT CONTENTS:

- 1- Skid Plate
- 1- Upper Control arm bracket
- 1- Drivers side bracket
- 1- Passengers side bracket
- 2- Front mounting bracket
- 2- Middle mounting bracket
- 2- Rear mounting bracket
- Hardware bag

### TOOLS NEEDED:

- 15mm socket or wrench
- 18mm socket or wrench
- 19mm socket or wrench
- Floor Jack
- Jack Stands

### HARDWARE INCLUDED:

- 10- M10-1.25 x 20mm Bolts
- 10- M10-1.25 Flange Nuts
- 10- M10 Flat Washers

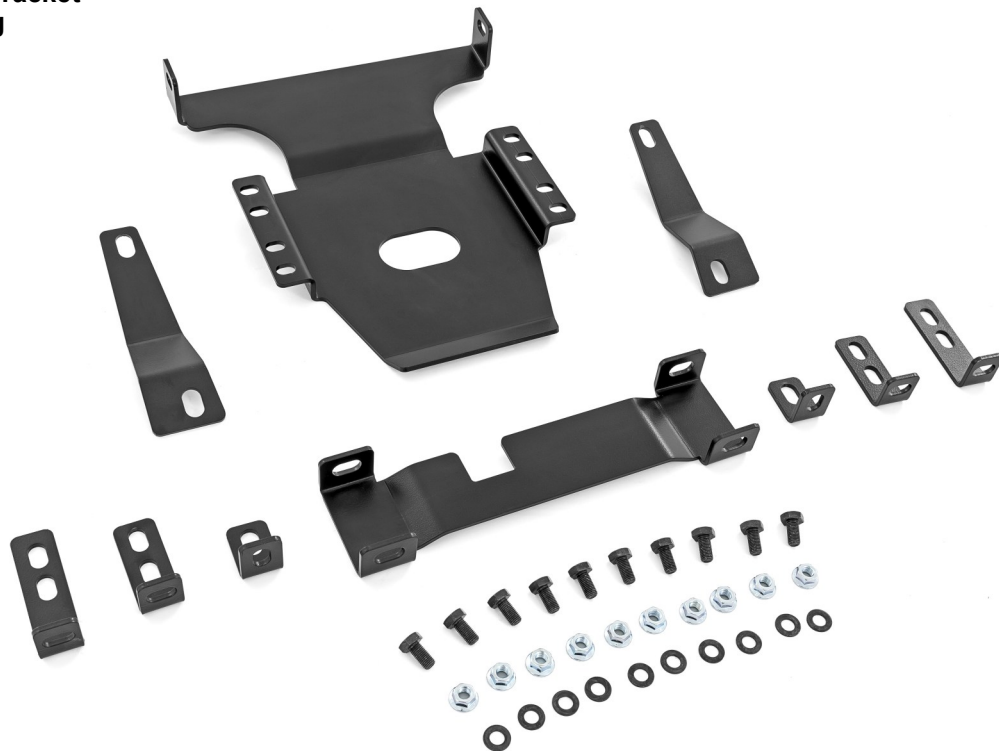

### Torque Specs:

Size	Grade 5	Grade 8	Size	Class 8.8	Class 10.9
5/16"	15 ft/lbs	20ft/lbs	6MM	5ft/lbs	9ft/lbs
3/8"	30 ft/lbs	35ft/lbs	8MM	18ft/lbs	23ft/lbs
7/16"	45 ft/lbs	60ft/lbs	10MM	32ft/lbs	45ft/lbs
1/2"	65 ft/lbs	90ft/lbs	12MM	55ft/lbs	75ft/lbs
9/16"	95 ft/lbs	130ft/lbs	14MM	85ft/lbs	120ft/lbs
5/8"	135ft/lbs	175ft/lbs	16MM	130ft/lbs	165ft/lbs
3/4"	185ft/lbs	280ft/lbs	18MM	170ft/lbs	240ft/lbs



## INSTALLATION INSTRUCTONS

1. Lift UTV and place on jack stands, then, using 19mm socket, remove front wheels and tires.
2. If UTV has front bumper, using 15mm socket, remove bumper.
3. Remove control arm bolts, retaining hardware, using 18mm socket. **See Photo 1 & 2.**

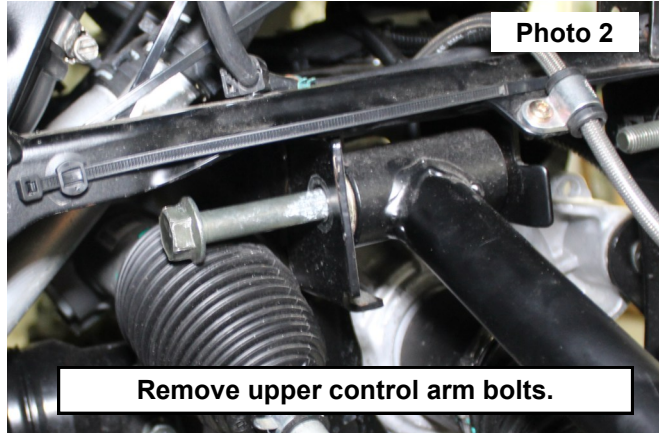
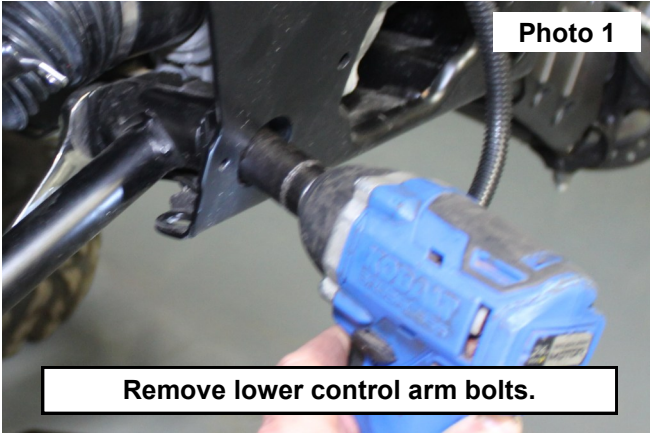

4. Install DR and Pass control arm support brackets using control arm bolts. **See Photo 3 & 4.**

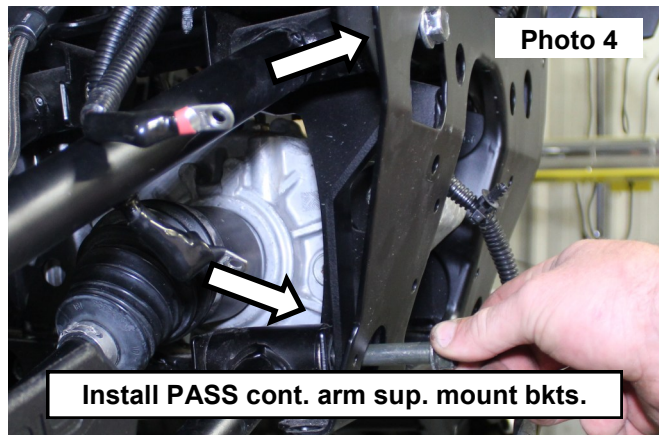
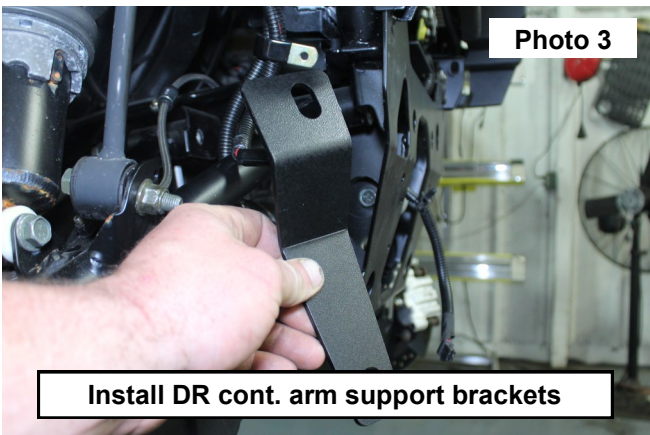

5. Loosely install front skid plate mount brackets. **See Photo 5.**
6. Loosely install middle skid plate mount brackets. These brackets will use retained control arm bolts. **See Photo 6.**

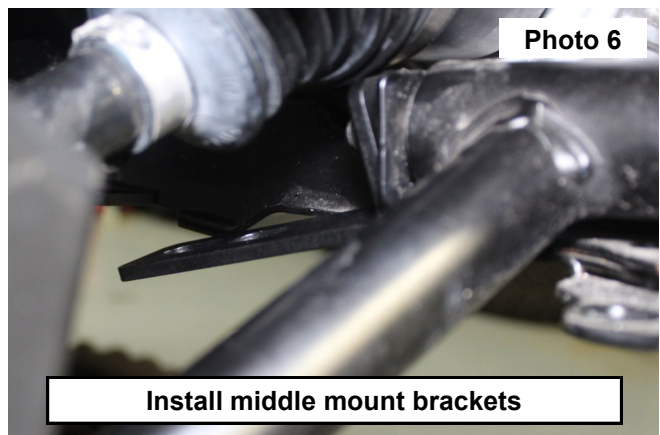
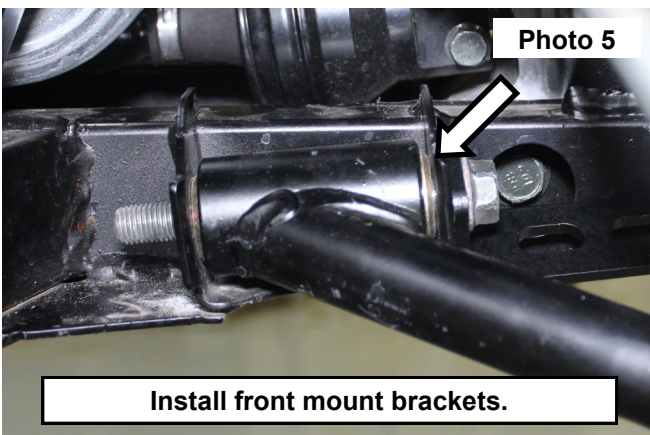



7. Install upper control arm bracket using retained control arm bolts. Do not tighten bolts. **See Photo 7 & 8.**

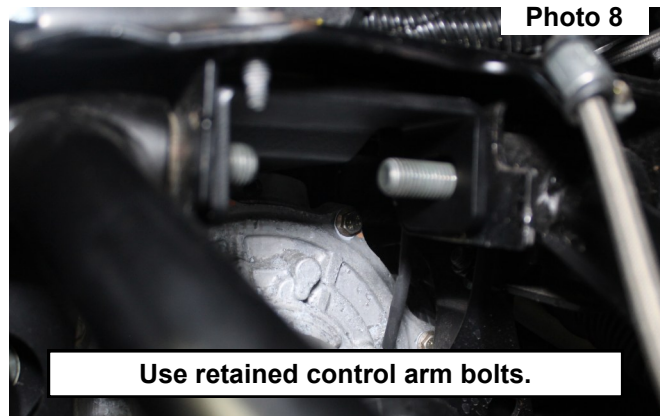
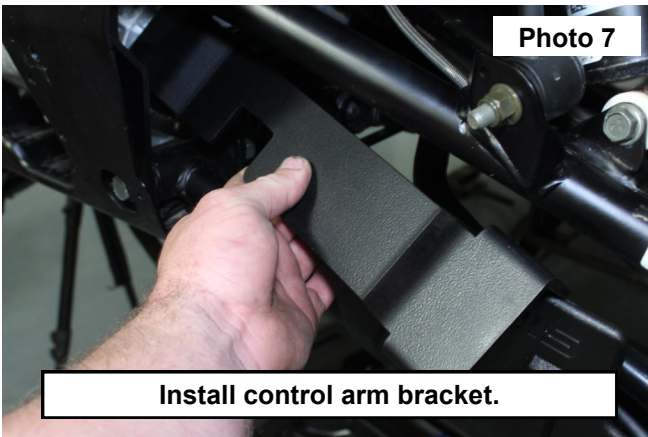

8. Place supplied 10mm bolts in mounting holes on the front and middle mount brackets. **See Photo 9.**  
9. Install skid plate on 10mm bolts. Do not tighten. **See Photo 10.**

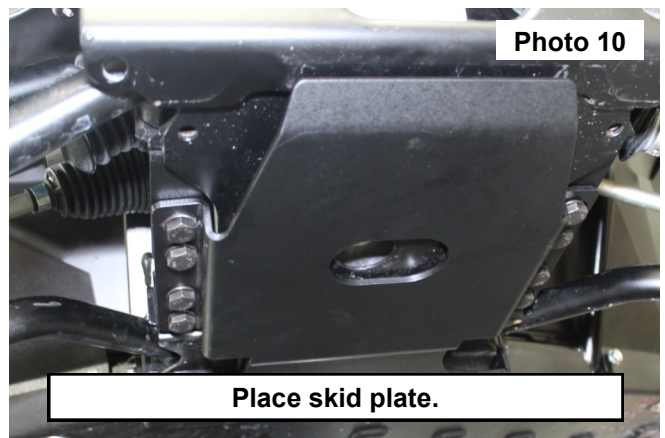
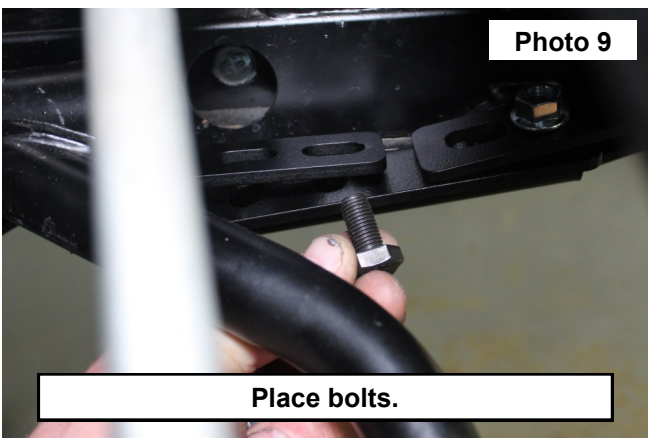

10. Tighten control arm bracket with 18mm socket and wrench. **See Photo 11.**  
11. Install rear mount bracket on control arm bolt, and install on to skid plate. Do not tighten. **See Photo 12.**  
12. Moving from front to rear, begin tightening all hardware.

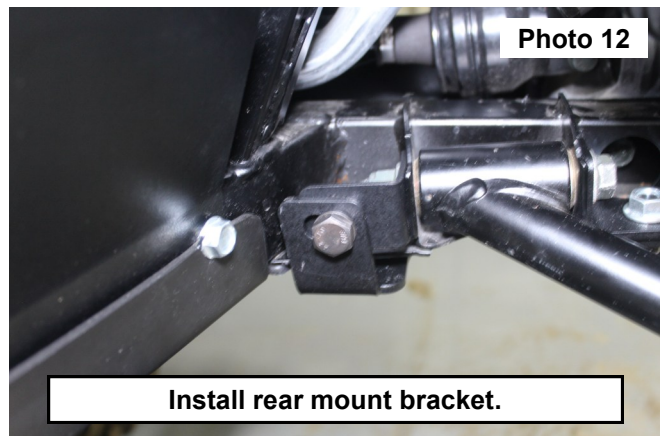
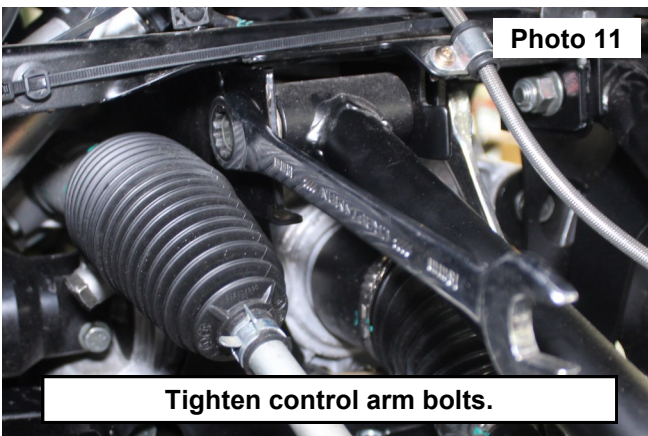

By purchasing any item sold by Rough Country, LLC, the buyer expressly warrants that he/she is in compliance with all applicable, State, and Local laws and regulations regarding the purchase, ownership, and use of the item. It shall be the buyers responsibility to comply with all Federal, State and Local laws governing the sales of any items listed, illustrated or sold. The buyer expressly agrees to indemnify and hold harmless Rough Country, LLC for all claims resulting directly or indirectly from the purchase, ownership, or use of the items.

