

ROUGH COUNTRY

SUSPENSION SYSTEMS®

Nissan Frontier Exhaust System

Fits w/ 3.8 Engine Exhaust

Thank you for choosing Rough Country for all your vehicle needs.

Please read instructions before beginning installation. Check the kit hardware against the kit contents shown below. Be sure you have all needed parts and know where they go.

If question exist, please call us @1-800-222-7023. We will be happy to answer any questions concerning this product.

Check all fasteners for proper torque. Check to ensure for adequate clearance between all components.

Periodically check all hardware for tightness.

KIT CONTENTS:

- Dr side Inlet Tube w/ Flange x1 (A)
- Dr Side Rear Inlet Pipe (B)
- Pass Side Inlet Tube w/ Flange x1 (C)
- Muffler x1 (D)
- Hanger Clamp x1 (E)
- Rear Tube x1 (F)
- Passengers Side Exit Tube x1 (G)
- Exhaust Tip x1 (H)
- Clamps x4

TOOLS NEEDED:

- 10mm Socket
- 12mm Socket
- 14mm Socket
- 15mm Socket



Torque Specs:

Size	Grade 5	Grade 8	Size	Class 8.8	Class 10.9
5/16"	15 ft/lbs	20ft/lbs	6MM	5ft/lbs	9ft/lbs
3/8"	30 ft/lbs	35ft/lbs	8MM	18ft/lbs	23ft/lbs
7/16"	45 ft/lbs	60ft/lbs	10MM	32ft/lbs	45ft/lbs
1/2"	65 ft/lbs	90ft/lbs	12MM	55ft/lbs	75ft/lbs
9/16"	95 ft/lbs	130ft/lbs	14MM	85ft/lbs	120ft/lbs
5/8"	135ft/lbs	175ft/lbs	16MM	130ft/lbs	165ft/lbs
3/4"	185ft/lbs	280ft/lbs	18MM	170ft/lbs	240ft/lbs



INSTALLATION INSTRUCTIONS

1. Loosen the bolts on the flange of the driver and passenger side pipe using a 14 mm socket. **See Photo 1 & 2.**

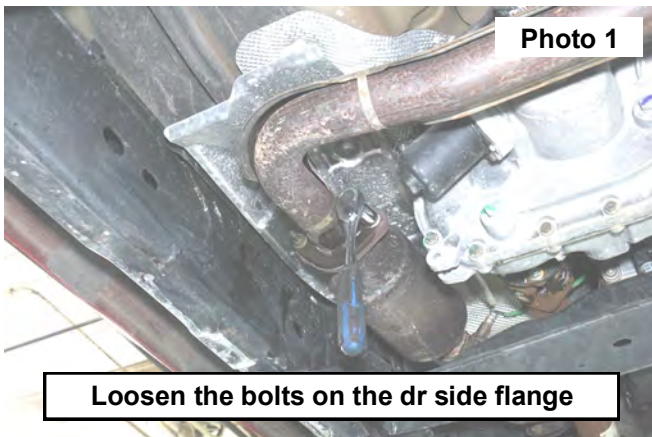

Loosen the bolts on the dr side flange

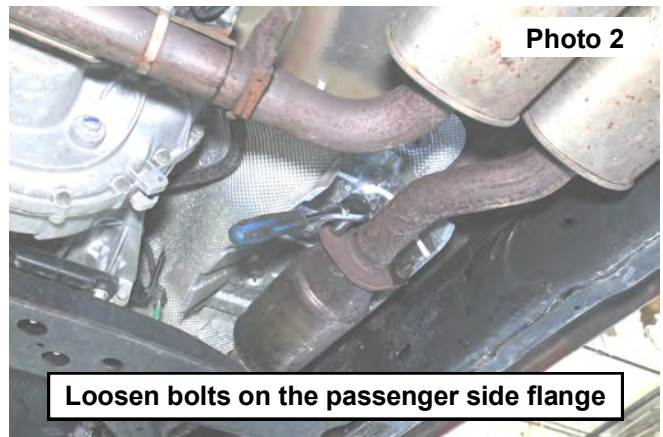

Loosen bolts on the passenger side flange

2. Using a 15 mm socket, loosen the pipe clamp shown. **See Photo 3.**
3. Using a 12 mm socket, remove the two bolts securing the exhaust hangers on the crossmember. **See Photo 4.**

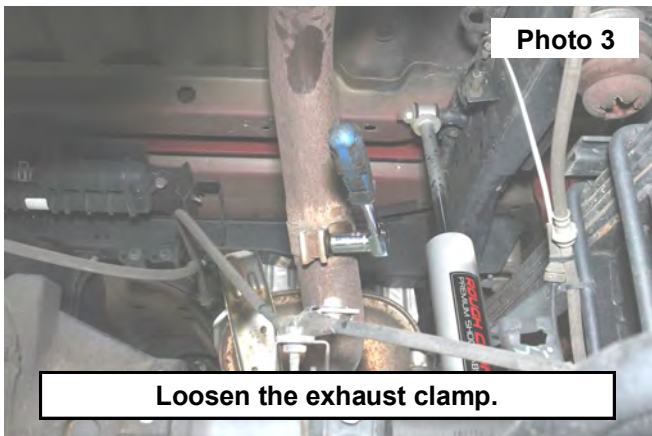

Loosen the exhaust clamp.

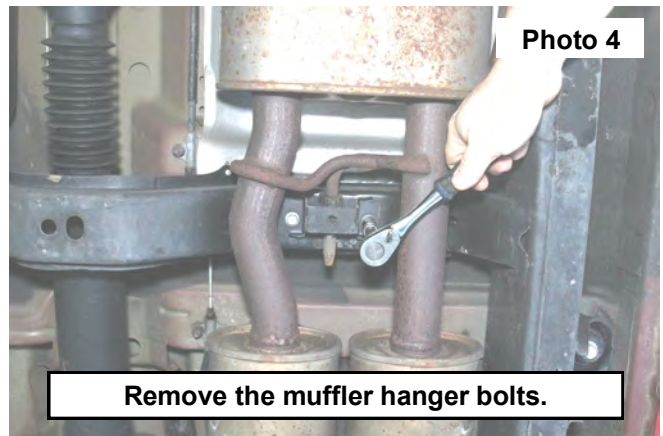

Remove the muffler hanger bolts.

4. Using a 12 mm socket remove the 3 bolts on the side of the frame rail. **See Photo 5.**
5. Remove the factory exhaust. **See Photo 6.**

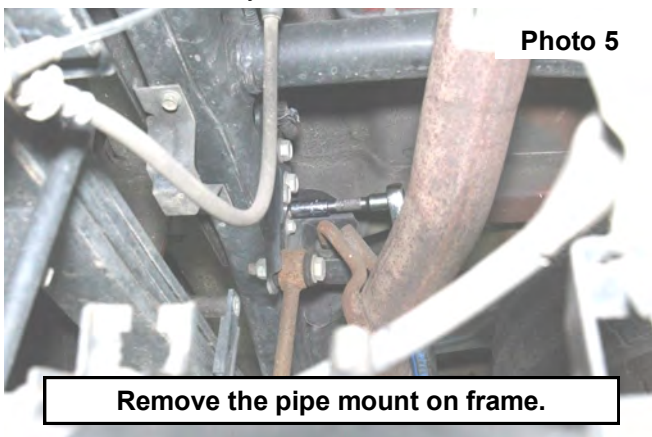

Remove the pipe mount on frame.

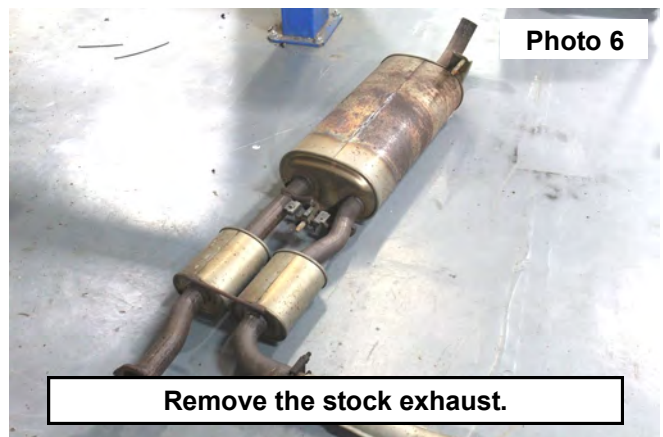

Remove the stock exhaust.

6. Locate and install the driver side pipe "A" on the factory flange using stock hardware. **See Photo 7.**
7. Locate and install the driver side pipe "B" as shown with new pipe clamp and the passenger side pipe "C" on the factory flange utilizing the stock hangers and using stock hardware. **See Photo 8.**

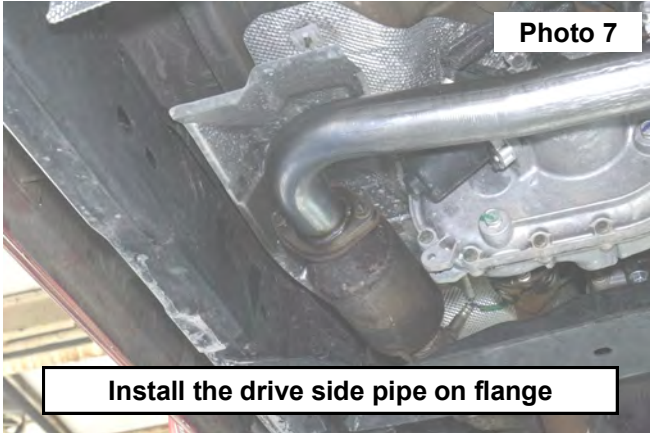

8. Install the muffler "D" on the driver and passenger side pipes and secure to the pipes using supplier pipe clamps. **See Photo 9.**
9. Install the supplied hanger clamp "E" on the rear of the muffler. **See Photo 10.**

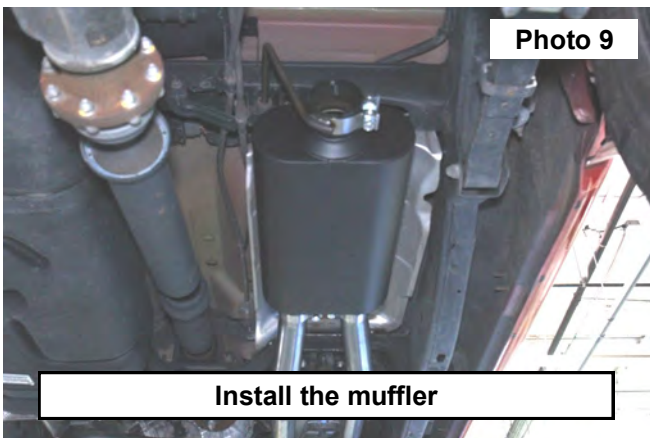

10. Locate and install the rear pipe "F" as shown in **Photo 11 & 12**

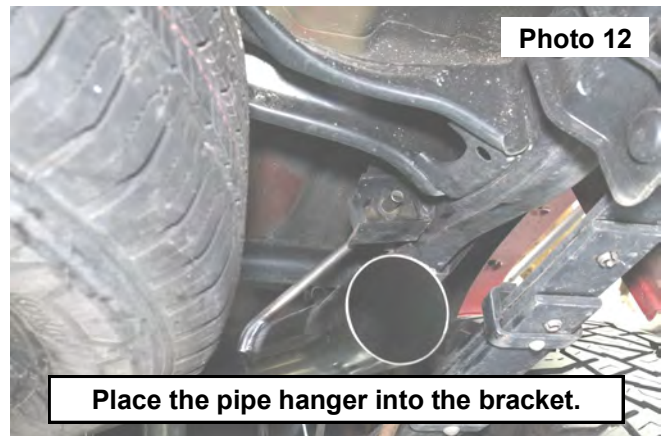
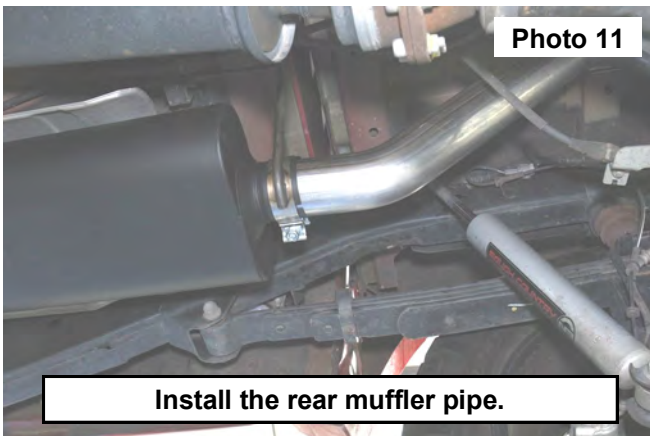

11. Locate the exit pipe "G" as shown in **Photo 13** and install the rear angled exit pipe as shown in **Photo 14** using the supplied pipe clamp.

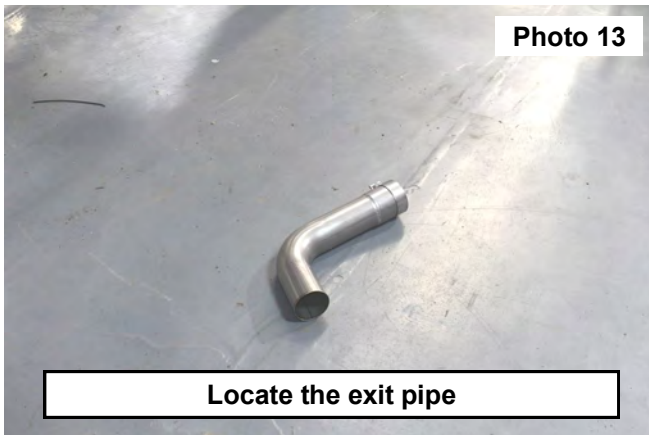

12. Install the tip "H" as shown in **Photo 15**.
13. Tighten all clamps using a 15 mm socket and all stock hangers with a 12 mm socket. Tighten the exhaust flanges using a 14 mm socket.
14. Adjust the location of the tip as desired and tighten clamp using a 10 mm socket. **See Photo 16.**

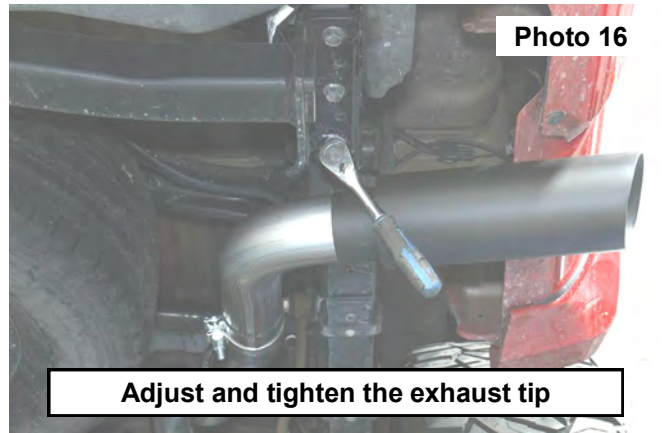
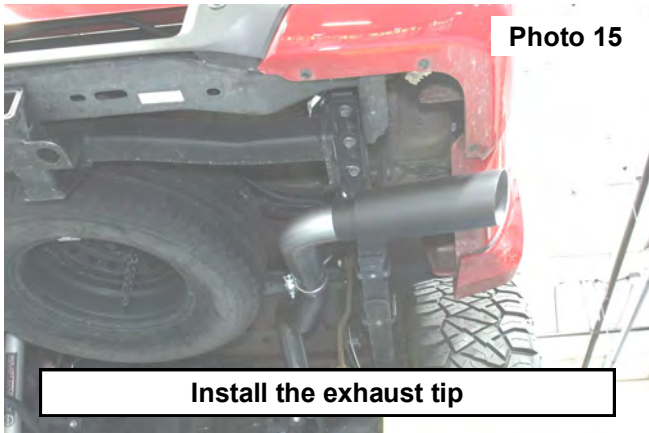

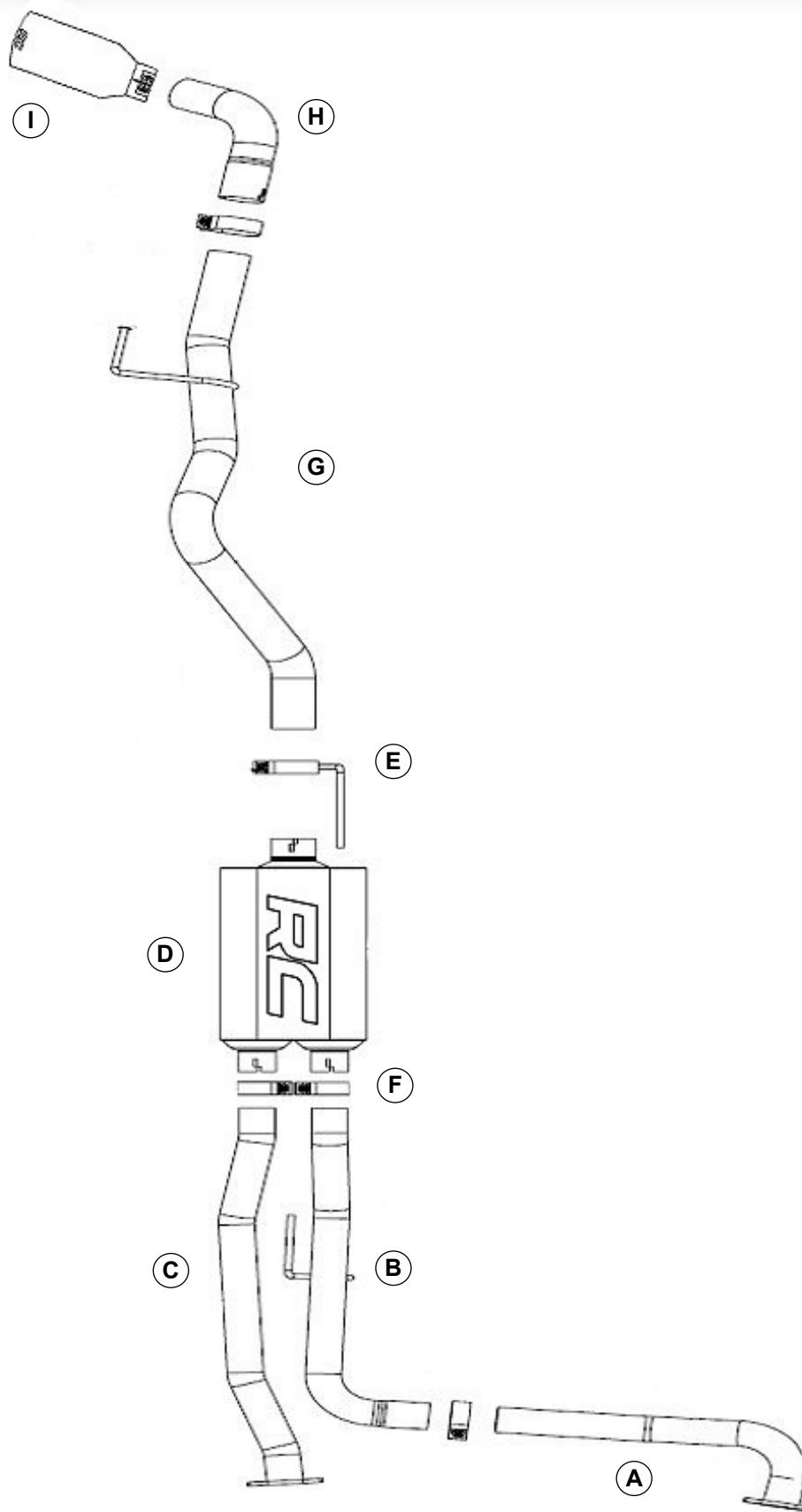

By purchasing any item sold by Rough Country, LLC, the buyer expressly warrants that he/she is in compliance with all applicable, State, and Local laws and regulations regarding the purchase, ownership, and use of the item. It shall be the buyers responsibility to comply with all Federal, State and Local laws governing the sales of any items listed, illustrated or sold. The buyer expressly agrees to indemnify and hold harmless Rough Country, LLC for all claims resulting directly or indirectly from the purchase, ownership, or use of the items.

