



INSTALLATION INSTRUCTIONS

1075 North Ave. Sanger, CA 93657-3539 local: 559-875-0222 fax: 559-876-2259 toll free: 800-445-3767

5521 REAR ANTI-SWAY BAR 2004 CHEVY COLORADO

Congratulations! You were selective enough to choose a BELLTECH PRODUCT. We have spent many hours developing our line of products so that you will receive maximum performance with minimum difficulty during installation.

Note: Confirm that all of the hardware listed in the parts list is in the kit. **Do not** begin installation if any part is missing. Read the instructions thoroughly before beginning this installation.

Warning: **DO NOT** work under a vehicle supported by only a jack. Place support stands securely under the vehicle in the manufacturer's specified locations unless otherwise instructed.

Warning: **DO NOT** drive vehicle until all work has been completed and checked. Torque all hardware to values specified.

Reminder: Proper use of safety equipment and eye/face/hand protection is absolutely necessary when using these tools to perform procedures!

Note: It is very helpful to have an assistant available during installation.

RECOMMENDED TOOLS:

- Properly rated floor jack, support stands, and wheel chocks
- Combination wrench: 15mm
- Ratcheting socket wrench and sockets: 10mm 19mm
- Safety Glasses

KIT INSTALLATION

1. Open the hardware kit and remove all of the contents. Refer to the part list (Page 3) to verify that all parts are present.
2. Park the vehicle on a smooth, level concrete or seasoned asphalt surface and activate the parking brake. Block the FRONT wheels of the vehicle with appropriate wheel chocks; making sure the vehicle's transmission is in 1st gear (manual) or "Park" (automatic).
3. Using a properly rated floor jack, lift the rear wheels of the vehicle off the ground. Place support stands, rated for the vehicle's weight, and in the factory specified locations. Refer to the vehicle Owner's Manual. Prior to lowering the vehicle onto the stands, make sure the supports will securely contact the chassis.

It is very important that the vehicle is properly supported during this installation to prevent personal injury and chassis damage! Make sure that the supports stands are properly placed prior to performing the following procedures. We **DO NOT RECOMMEND** using wheel ramps while performing this installation.

4. Slowly lower the vehicle onto the stands and, before placing the vehicle's entire weight on them, again check that they properly and securely contact the chassis as described above. Check for possible interference with any lines, wires, cables, or other easily damaged components.

5. Thoroughly lubricate the inside of the new polyurethane bushings using the grease provided. Locate the bushings on the ends of the Belltech Anti-Sway Bar (Photo 1,2). Once located, rotate the bushings slightly too evenly spread the lubricant.

WD-40™ is recommended to help remove excess lubricant. Re-greasing the pivot bushings should be performed at regular intervals. Climate and driving conditions will govern the time between services. Remember to check all hardware while performing bushing maintenance.

6. Insert the bar from under the vehicle positioning it behind the axle with the bar ends pointed toward the rear of vehicle and angled up (Photo 1, 4). Once in position, start from one side and place one U-bolt, saddle, and bushing support plate around the axle. While holding the U-bolt with one hand attach the Anti-Sway Aar bushing clamp with the other, and loosely thread the hardware into place. Do the same to the other side (Photo 2, 3). Center the bar from side to side and horizontally on the axle then tighten the U-bolts to the axle.
7. Next Attach the end links to the Bar end holes beneath the shock mounts (Photo 4). Install the new end-link bolts with the cupped washers and grommets from above so that the heads face up and the lock nuts will be located at the bottom. Thread the lock nuts on by hand. Make sure to install both sides before nuts are tightened. Use the 9/16" wrench and 9/16" socket to tighten the end-link hardware.
8. Next you will need to drill a hole on each side of the frame and attach an end link bracket to it. To do this you will need to make sure the vehicle weight is on the axle so that we can mark the mounting location for the bracket holes beneath the shock mounts (Photo 4). Install the new end-link bolts with the cupped washers and grommets from above so that the heads face up and the lock nuts will be located at the bottom. Thread the lock nuts on by hand. Make sure to install both sides before nuts are tightened. Use the 9/16" wrench and 9/16" socket to tighten the end-link hardware
9. The end-link bracket must be installed next; to do this you will need to mark the frame straight up from the holes on the anti-sway bar. Next mark 1" from the bottom of the frame, (photo 4) center punch and drill that spot with a 1/2" drill bit. This hole will go through both sides of the frame. Then, on the inside of the frame, using the 1/2" hole as reference, drill a 3/4" hole. This hole is for the spacer tube clearance and is only required on the inside of the frame. Reference the bracket to the right location (if lowered vehicle swing bracket up, if stock height swing bracket down), install spacer tube, from the inside of the frame, and appropriate hardware. Tighten to 20ft. lbs.

All hardware being fastened to the vehicle's original fastening points should be torqued to the proper specifications. To prevent chassis damage, never over-torque the hardware.

10. Install the new end-links (Photo 5). Install the bolts with the cupped washers and grommets from above so that the heads face up and the lock nuts will be located at the bottom. Thread the lock nuts on by hand. Use the 14mm wrench and socket to tighten the end-link hardware. Tighten only until the urethane end-link grommets just begin to bulge. Tighten the u-bolt hardware evenly to 20ft. lbs.
11. Check that all components and fasteners have been properly installed, tightened and torqued.
12. Check brake hoses, and other components for any possible interference.
13. Lift vehicle and remove support stands. Carefully lower vehicle to ground.
14. Immediately test-drive the vehicle in a remote location so that you can become accustomed to the revised driving characteristics and handling. Be aware that the vehicle will handle substantially different now that it has been modified.

15. Installation is complete. Check all of the hardware and re-torque at intervals for the first 10, 100, 1000 miles.

PART LIST FOR 5521 ANTI-SWAY BAR KIT

PART#	DESCRIPTION	QTY
5521-300	Rear ASB	1
112258	U-Bolt Kit 3"	2
114038	Under Support Plate	2
113075	Pivot Bushing	2
114026	Bushing Bracket	2
110255	3/8-16 Nylon Lock Nut	6
5524-003	Angle Bracket	2
112212	1/2-13 x 3-1/2" HH Cap Screw	2
112538	1/2 Flat Washer USS	4
112138	3/8-16 x 6 1/2" HH Cap Screw	2
112424	Spacer Tube	2
112502	Cupped Washer	8
7000-886	Grommets	8
6612-014	Spacer Tube	2
110400	1/2-13 Flange Nut	2
55000-10	Grease Pack	1

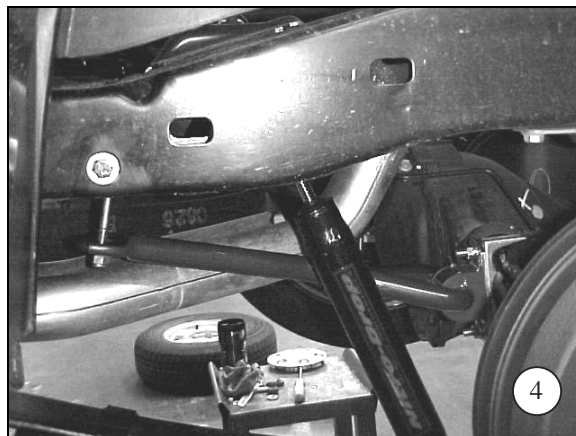
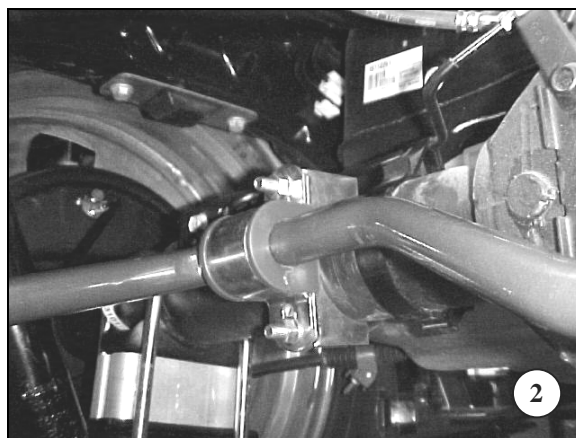
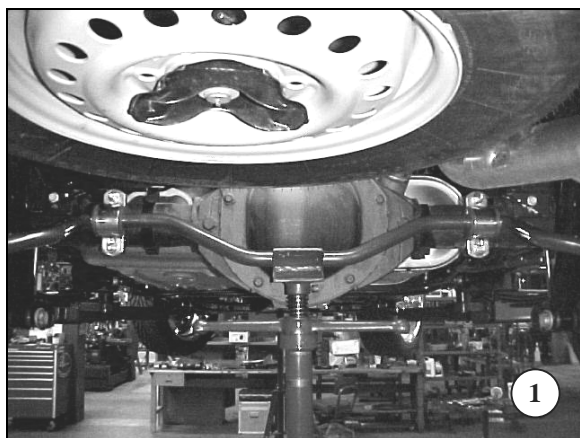

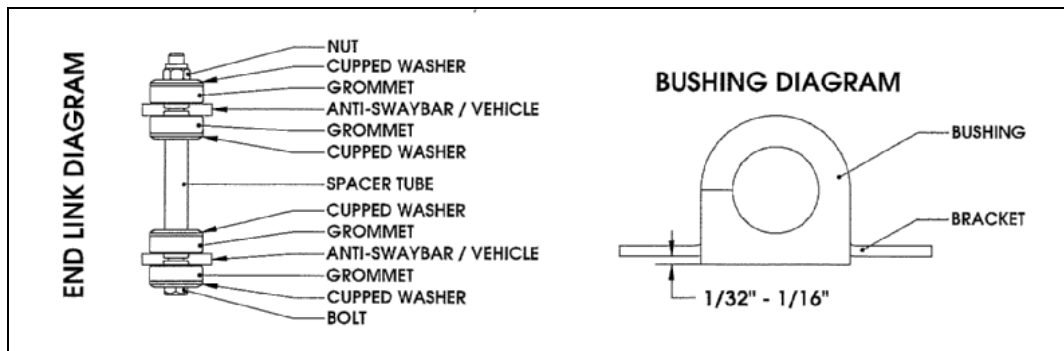

PHOTO 5

! BELLTECH INSTALLATION TIPS

LUBRICATION

Pre-lubricating a bushing before its installed is important because the lubrication will greatly reduce noise and it will increase bushing life. Belltech recommends you use Molybdenum disulfide. This will help protect the inside surface of the bushing and will last longer than most types of grease. Thoroughly lubricate the inside of the bushing with this grease.



BUSHING INSTALLATION

Make sure an amount of 1/32" to 1/16" of the bushing is showing when you install it onto the bracket. If the bushing is showing more than 1/16" than use a sander or a sheet of coarse grit sand paper to shave it down to the proper height. In most applications when installing the new bushings on your Belltech Anti-Sway Bar you may refer to your original equipment Anti-Sway Bar to locate the proper location. See the END LINK DIAGRAM above.