

## Introduction

The items included in the 52300 upgrade kit are intended to replace the air line, air fittings and Schrader valves in compatible LoadLifter 5000 and LoadLifter 5000 Ultimate kits. This kit may require additional clearance between the top of the air spring and upper bracket in order to properly install the new fittings and braided stainless steel air lines in this application. Air Lift recommends verifying that there is adequate clearance to install the air line components to avoid installation difficulty. In addition to the pieces in the kit 52300, kit 52301 also includes roll plates and air spring mounting hardware.

In order to install the upgraded roll plates and air spring hardware, the air spring assembly must be removed from the vehicle. Check the condition of the existing hardware before removing. Refer to the installation manual that came with the kit or look it up on the Air Lift website at [www.AirLiftCompany.com](http://www.AirLiftCompany.com). Instructions for installing the braided stainless steel air lines are included in this installation guide.

### NOTE

*Kit No. 52301 includes extra hardware in order to accommodate many Air Lift LoadLifter 5000 kits. The parts in this kit do not replace the bracket-to-chassis mounting hardware. There will be hardware left over after installation.*

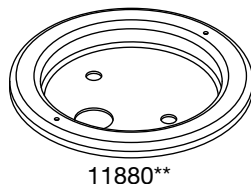
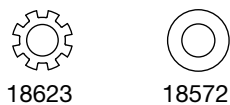
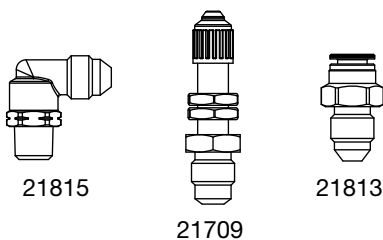
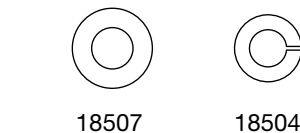

### Hardware list (52300)

PART#	DESCRIPTION	QTY
21815	Nickel-plated brass AN-type fitting.....	2
20987	Stainless steel braided air line*.....	2
18572	M8 Stainless steel flat washer.....	2
18623	Stainless steel star washer.....	2
21709	Nickel-plated brass fill valve w/ cap & nuts.....	2
10466	Zip tie*.....	12
21813	Nickel-plated brass PTC-to-AN adapter fitting ...	2
20084	Air line assembly*.....	1

### Hardware list (52301)

PART#	DESCRIPTION.....	QTY
11880	Stainless steel roll plate.....	4
21815	Nickel-plated brass AN-type fitting.....	2
17363	3/8"-24 x 3/4" Stainless steel flat-head screw ....	8
17284	3/8"-24 x 7/8" Stainless steel hex-head bolt.....	8
17376	3/8"-24 x 7/8" Stainless steel button-head bolt...4	4
18504	3/8" Stainless steel lock washer.....	8
18507	3/8" Stainless steel flat washer.....	8
20987	Stainless steel braided air line*.....	2
18572	M8 Stainless steel flat washer.....	2
18623	Stainless steel star washer.....	2
21709	Nickel-plated brass fill valve w/ cap & nuts.....	2
10466	Zip tie*.....	12
21813	Nickel-plated brass PTC-to-AN adapter fitting ...	2
20084	Air line assembly*.....	1

\*\* Not to scale \* Not shown

# Installing the Air Spring Mounting Hardware and Roll Plates

1. Locate and reference the installation guide that came with the LoadLifter 5000 Series air spring kit for this vehicle. Download an electronic copy at [AirLiftCompany.com](http://AirLiftCompany.com).
2. Exhaust all air from the system. See “Replacing Existing Nylon Air Lines” section below.
3. Remove the air spring from the brackets following the steps found in the installation guide in reverse order.
4. There are three styles of air spring mounting hardware used for LoadLifter 5000 Series kits. Determine which combination of hardware is required for this application (Fig. 1).

## Mounting Hardware for Typical Air Spring Assembly

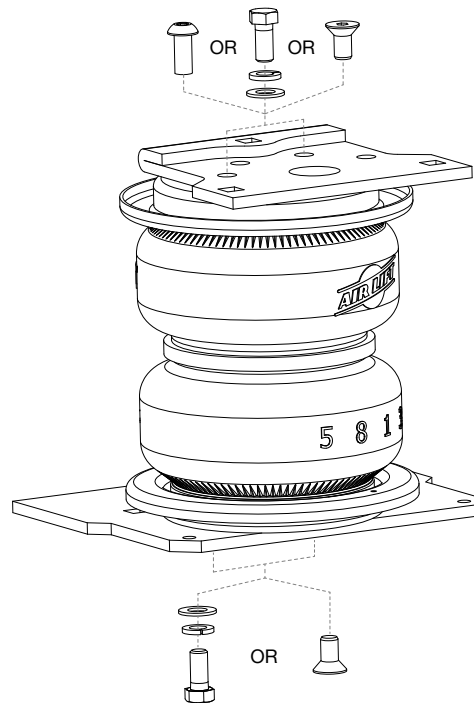

Torque air spring mounting hardware to no more than 20 lb.-ft. (27Nm).

*fig. 1*

5. Follow the instructions in this guide and the original installation guide to reassemble the kit using the upgrade components.

# Replacing Existing Nylon Air Lines

1. Exhaust all air from the system, either with the Schrader valves or the on-board air compressor system (if equipped). If the vehicle has a compressor system, remove the fuse to prevent the system from trying to inflate the air springs while working on the vehicle.
2. To disconnect PTC fittings, push in on the air line (step 1), push the collar (step 2) and, with the collar depressed, pull the air line out of the fitting (step 3) (Fig. 2).
3. Remove the existing Schrader valve, nylon air line and air spring fitting.

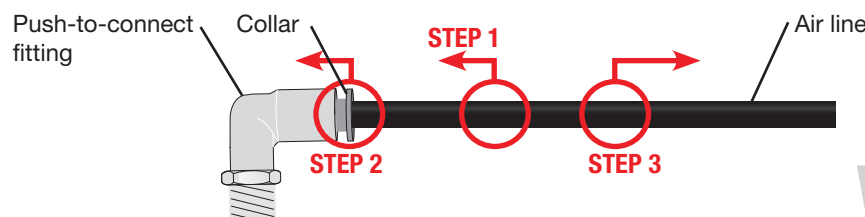

*fig. 2*



## INSTALLING BRAIDED STAINLESS STEEL AIR LINES

When using braided stainless steel air lines, the preferred location for the Schrader valve is the back of the vehicle. The bumper, license plate holes or bumper recess are all acceptable locations. The braided stainless steel air line cannot be trimmed (Fig. 3).

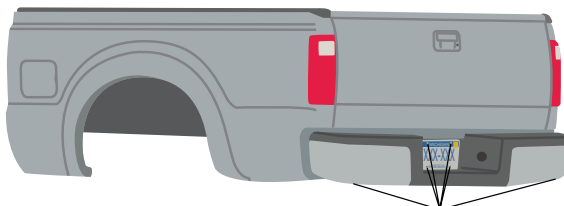

fig. 3

**CAUTION**

KEEP THE AIR LINE AWAY FROM THE FUEL LINE, BRAKE LINES AND ELECTRICAL WIRES.

1. Install the upgraded air spring fitting on the air spring finger tight plus 1 3/4 turns (Fig. 4).
2. Use zip ties to secure the air line to fixed points along the chassis every 6" to 8". Leave at least 2" of slack to allow for any movement that might pull on the air line.
3. Tighten the air line hex nut finger tight, then use 2 wrenches to turn 1 additional flat (1/6 of one full turn). **Do not overtighten** (Figs. 4, 5 & 6). The easiest way to tighten the fittings is off the vehicle. Install the Schrader valve in the chosen location.
4. Coil and secure any excess air line in an area where it will not be susceptible to damage.

### Air Spring Fitting

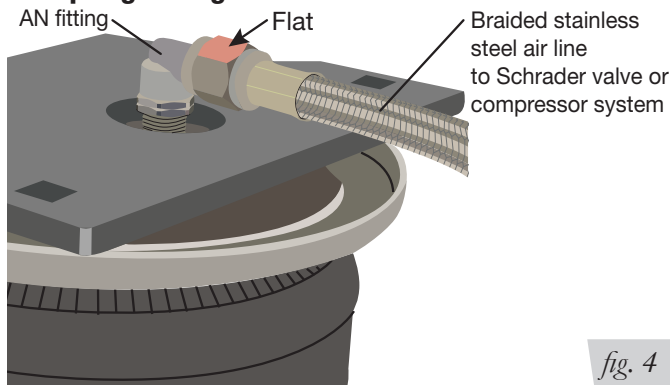

fig. 4

### Air Line Setup Without Compressor System

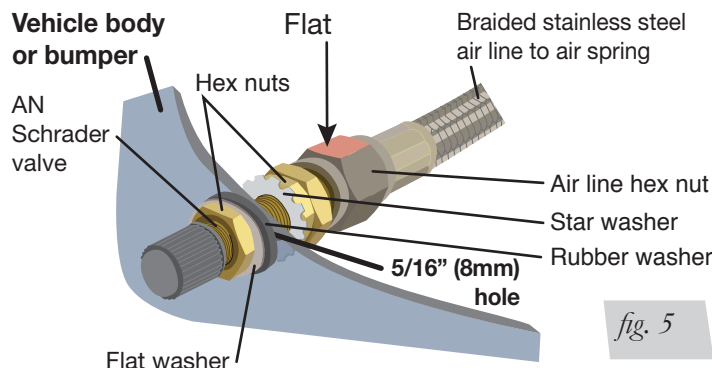
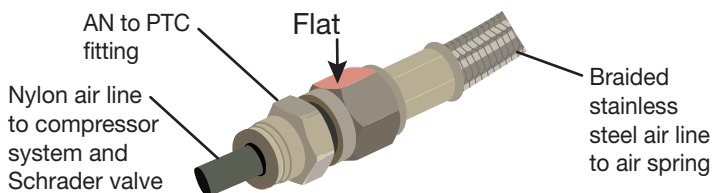

fig. 5

### Air Line Setup for Compressor Integration



If a compressor system is already installed, tap into the existing air lines.

fig. 6



*Thank you for purchasing Air Lift Products — the Authorized Installer's choice!*

## Limited Warranty and Return Policy

Air Lift Company provides a limited lifetime warranty to the original purchaser of its Load Support products, that the products will be free from defects in workmanship and materials when used on cars and trucks as specified by Air Lift Company and under normal operating conditions, subject to the requirements and exclusions set forth in the full Limited Warranty and Return Policy that is available online at [www.airliftcompany.com/warranty](http://www.airliftcompany.com/warranty).

For additional warranty information contact Air Lift Company customer service.

## Replacement Part Information

If replacement parts are needed, contact the local dealer or call Air Lift customer service at **(800) 248-0892**. Most parts are immediately available and can be shipped the same day.

**Contact Air Lift Company customer service at (800) 248-0892 first if:**

- Parts are missing from the kit.
- Need technical assistance on installation or operation.
- Broken or defective parts in the kit.
- Wrong parts in the kit.
- Have a warranty claim or question.

**Contact the retailer where the kit was purchased:**

- If it is necessary to return or exchange the kit for any reason.
- If there is a problem with shipping if shipped from the retailer.
- If there is a problem with the price.

## Contact Information

<b>Mailing address</b>	P.O. Box 80167 Lansing, MI 48908-0167
<b>Shipping address for returns</b>	2727 Snow Road Lansing, MI 48917
<b>Phone</b>	Toll free: (800) 248-0892 International: (517) 322-2144
<b>Email</b>	<a href="mailto:service@airliftcompany.com">service@airliftcompany.com</a>
<b>Web address</b>	<a href="http://www.airliftcompany.com">www.airliftcompany.com</a>

Air Lift Company • 2727 Snow Road • Lansing, MI 48917 or P.O. Box 80167 • Lansing, MI 48908-0167