

Load*LIFTER* **5000**[™] **ULTIMATE** ADJUSTABLE AIR HELPER SPRINGS



Kit Number
88215

INSTALLATION GUIDE

For maximum effectiveness and safety, please read these instructions completely before proceeding with installation.

Failure to read these instructions can result in an incorrect installation.

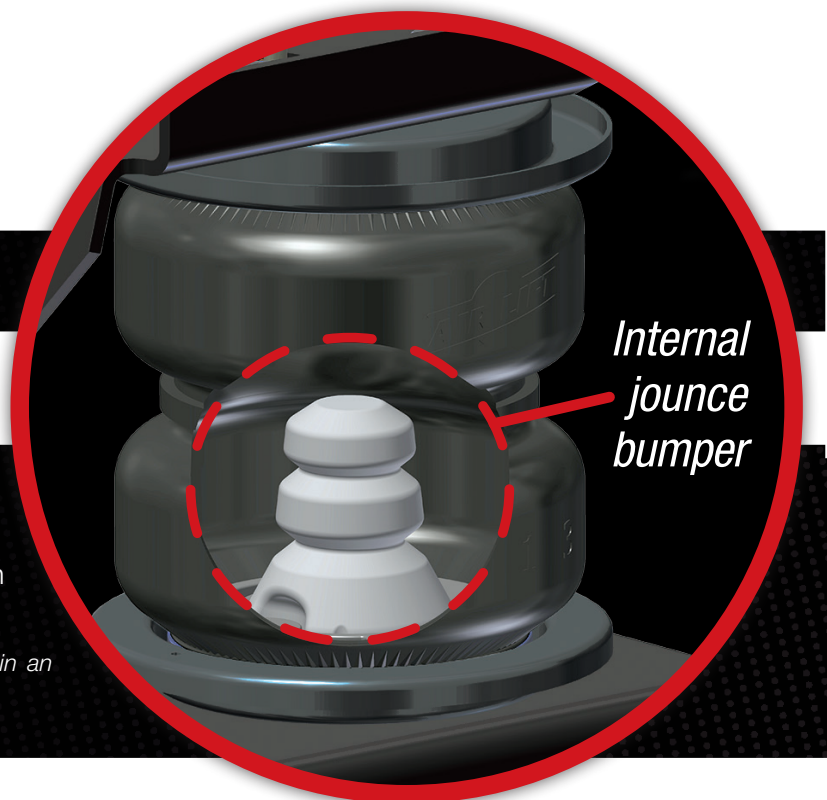
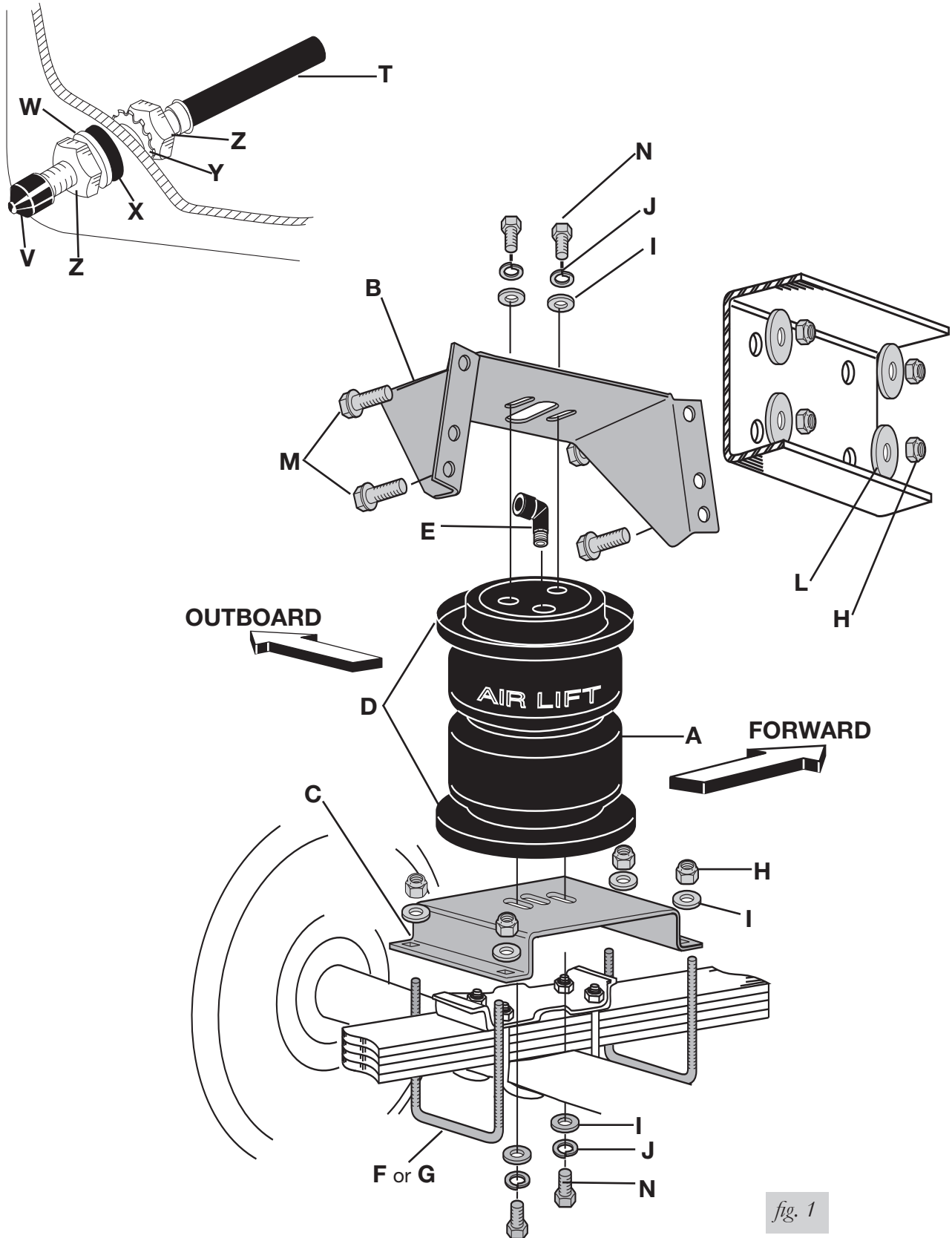

TABLE OF CONTENTS

Installation Diagram	2
Hardware List	3
Introduction	4
Important Safety Notice	4
Notation Explanation	4
Installing the LoadLifter 5000 Ultimate System	5
Getting Started	5
Special Application Instructions	6
Assembling the Air Spring Unit	7
Positioning the Brackets	8
Attaching the Lower Bracket	8
Attaching the Upper Bracket	9
Securing the Air Spring to the Brackets	10
Reinstalling the Fenderwell Liner — Late Model 4WD Dodge Only	11
Installing the Air Lines	12
Tips for Installing Air Lines	13
Before Operating	14
Checking for Leaks	14
Fixing Leaks	14
Installation Checklist	15
Post-Installation Checklist	15
Product Use, Maintenance and Servicing	16
Minimum and Maximum Pressure	16
Maintenance Guidelines	16
Tuning the Air Pressure	17
Guidelines for Adding Air	17
Troubleshooting Guide	18
Frequently Asked Questions	18
Limited Warranty and Returns Policy	21
Replacement Part Information	21
Contact Information	21

Installation Diagram



Hardware List

Item	Part #	Description.....Qty	Dodge Fenderwell Spacer Parts	
A	58496	Bellows2	P	17182 1/2" x 2" HHCS*2
B	07475	Upper bracket.....2	Q	20947 Fenderwell liner spacer*2
C	03102	Lower bracket.....2	R	18419 10/32" Flat washer*6
D	11967	Roll plate.....4	S	18425 1/4" Nylon lock nut*2
E	21837	Elbow fitting2	Air Line Assembly	
F	10594	2" U-bolt4	T	20086 Air line assembly*1
G	10583	4.5" U-bolt4	U	10466 Tie strap*6
H	18435	Nylon lock nut.....16	V	21230 Valve caps*2
I	18444	3/8" Flat washer.....16	W	18501 5/16" Flat washer*2
J	18427	3/8" Lock washer.....8	X	21234 Rubber washer*2
K	13377	Upper bracket spacer*8	Y	18411 Small star washer*2
L	18447	3/8" Large flat washer.....8	X	21233 5/16" Hex nut*4
M	17159	3/8" x 1.5" Washer head frame bolt ...8	*Not shown in fig. 1.	
N	17203	3/8" x 7/8" Hex head cap screw.....8		
O	01525	Spacer bar*4		



Missing or damaged parts? Call Air Lift customer service at (800) 248-0892 for a replacement part.

Introduction

The purpose of this publication is to assist with the installation, maintenance and troubleshooting of the LoadLifter 5000 Ultimate air spring kit. LoadLifter 5000 Ultimate utilizes sturdy, reinforced, commercial grade single or double, depending on the kit, convolute bellows. The bellows are manufactured like a tire with layers of rubber and cords that control growth. LoadLifter 5000 Ultimate kits are recommended for most 3/4- and 1-ton pickups and SUVs with leaf springs and provide up to 5,000 pounds of load-leveling support with air adjustability from 5-100 PSI.

It is important to read and understand the entire installation guide before beginning installation or performing any maintenance, service or repair. The information here includes a hardware list, tool list, step-by-step installation information, maintenance guidelines and operating tips.

Air Lift Company reserves the right to make changes and improvements to its products and publications at any time. For the latest version of this manual, contact Air Lift Company at **(800) 248-0892** or visit **airliftcompany.com**.

IMPORTANT SAFETY NOTICE

The installation of this kit does not alter the gross vehicle weight rating (GVWR) or payload of the vehicle. Check your vehicle's owner's manual and do not exceed the maximum load listed for your vehicle.

Gross vehicle weight rating: The maximum allowable weight of the fully loaded vehicle (including passengers and cargo). This number — along with other weight limits, as well as tire, rim size and inflation pressure data — is shown on the vehicle's Safety Compliance Certification Label.

Payload: The combined, maximum allowable weight of cargo and passengers that the truck is designed to carry. Payload is GVWR minus the base curb weight.

NOTATION EXPLANATION

Hazard notations appear in various locations in this publication. Information which is highlighted by one of these notations must be observed to help minimize risk of personal injury or possible improper installation which may render the vehicle unsafe. Notes are used to help emphasize areas of procedural importance and provide helpful suggestions. The following definitions explain the use of these notations as they appear throughout this guide.

 **DANGER**

INDICATES IMMEDIATE HAZARDS WHICH WILL RESULT IN SEVERE PERSONAL INJURY OR DEATH.

 **WARNING**

INDICATES HAZARDS OR UNSAFE PRACTICES WHICH COULD RESULT IN SEVERE PERSONAL INJURY OR DEATH.

 **CAUTION**

INDICATES HAZARDS OR UNSAFE PRACTICES WHICH COULD RESULT IN DAMAGE TO THE MACHINE OR MINOR PERSONAL INJURY.

NOTE

Indicates a procedure, practice or hint which is important to highlight.

Installing the LoadLifter 5000 Ultimate System

 **DANGER**

COMPRESSED AIR CAN CAUSE INJURY AND DAMAGE TO THE VEHICLE AND PARTS IF IT IS NOT HANDLED PROPERLY. FOR YOUR SAFETY, DO NOT TRY TO INFLATE THE AIR SPRINGS UNTIL THEY HAVE BEEN PROPERLY SECURED TO THE VEHICLE.

GETTING STARTED

1. Support the axle with jack stands, remove the wheels, and raise or lower to obtain normal ride height (Figs. 2 & 3).

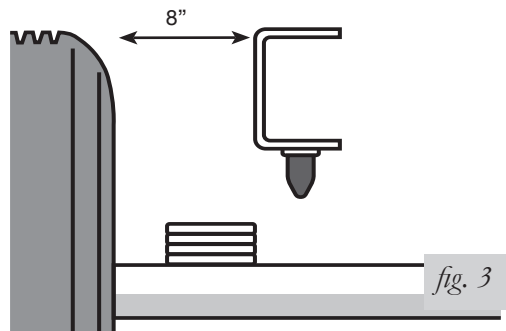
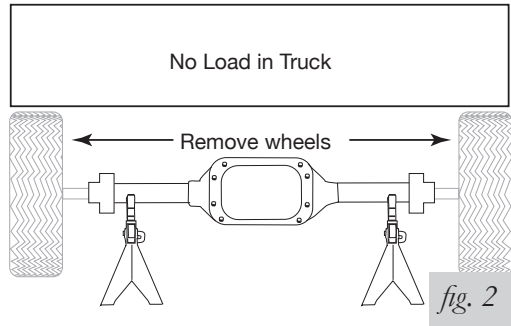

SPECIAL APPLICATION INSTRUCTIONS

1. 1994 model and newer Dodge 4WD pickups only:

It will be necessary to remove the inner fenderwell liner on late model 4WD Dodge trucks. This is done by carefully driving the pin through the fasteners with a center punch (Fig. 4). These fasteners will be reused along with a special spacer to reattach the line and provide clearance for the air spring. (See page 10 for reinstallation instructions.)

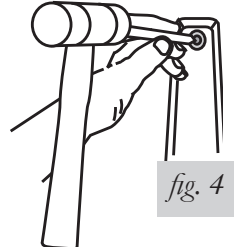

2. Ford trucks only:

When installing the upper bracket on an F-250 or F-350, the mounting bolt holes can line up directly over the indent in the frame. This is an acceptable situation and is an approved method of installation for the product (Fig. 5). Torque the mounting hardware to specifications, as noted. Do not over torque.

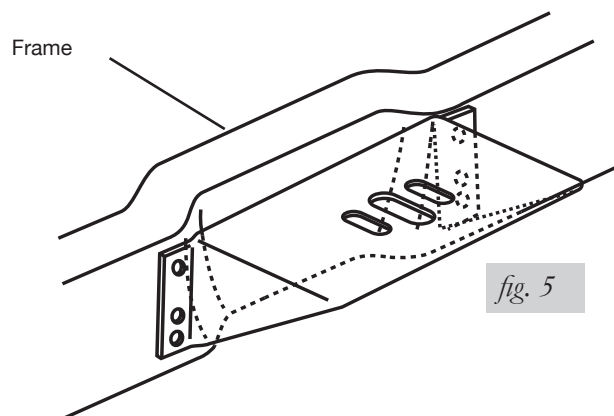

3. For 1999 and later SuperDuty F-250 and F-350 trucks:

Remove the bolt which holds the emergency brake cable to the outside of the frame rail. Reinstall the bolt in the reverse order, with the nut on the inside of the frame rail, to prevent rubbing against the air spring (Fig. 6).



FAILURE TO SWITCH THIS BOLT WILL CAUSE AIR SPRING TO RUPTURE.

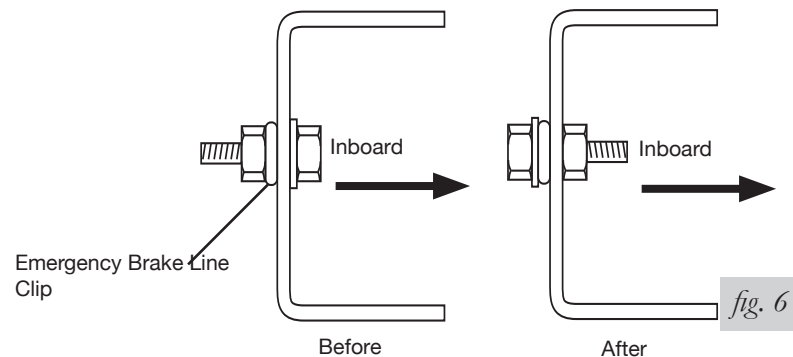

ASSEMBLING THE AIR SPRING UNIT

See Fig. 7 below for assembly.

1. Set a roll plate on both ends of the air spring. The radiused (rounded) edge of the roll plate will be towards the air spring so that the air spring is seated in both roll plates.
2. Install a 90° swivel air fitting. It should only be finger tight plus 1 1/2 turns. Do not overtighten.
3. Place the upper bracket onto the top of the air spring and roll plate with the legs facing down.
4. Set the air spring on the lower bracket aligning the two holes in the base of the air spring with the two outer slots in the top of the lower bracket.
5. Loosely attach the upper bracket to the assembly using flat washers, lock washers, and hex head bolts. Remember that the bracket legs face down.
6. Loosely attach the lower bracket to the assembly using flat washers, lock washers, and hex head bolts.

NOTE

The flange on the bracket must face the outside (tire-side) of the vehicle.

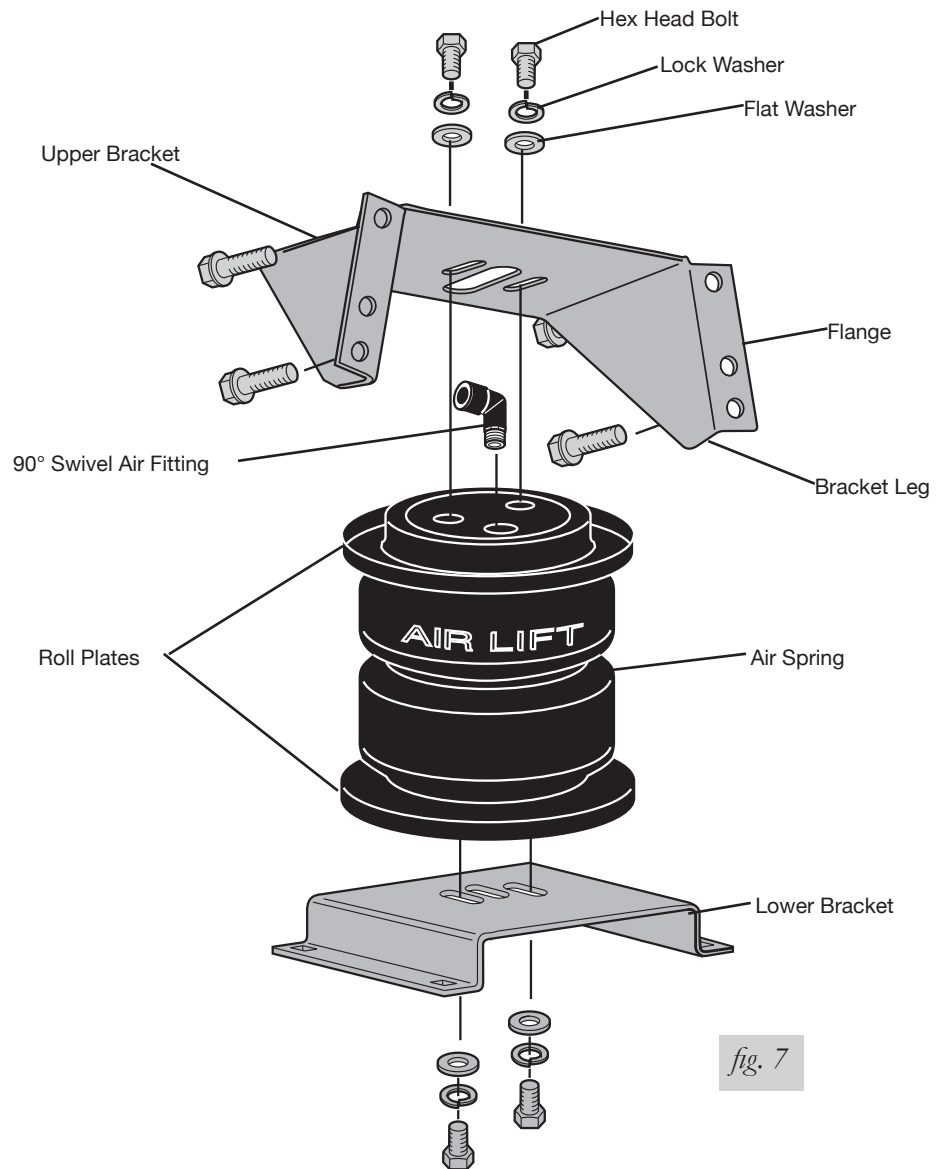

fig. 7

POSITIONING THE BRACKETS

1. The air spring must be installed between 5" and 7" from both the upper bracket to the lower bracket (Fig. 8). It is best to position the upper bracket as high as possible.

NOTE

Failure to mount the air spring at the recommended height can result in the air spring bottoming out.

The top rear mounting hole may be above the frame rail. If this condition exists, use the two lower mounting holes to mount the bracket (Fig. 8).

2. Set the air spring assembly on the leaf spring over the axle (Fig. 8).
3. Position the upper bracket so that at least four bolt holes (two on each side) will be on the flat section of the frame rail. Keep the edge of drilled holes no closer than 3/4" from the top or bottom radius of the frame rail.
4. In some cases, it may be necessary to use the optional spacers to achieve the 5" - 7" space (Fig. 8). For example, if only the top two holes contact above the lower radius edge of the frame rail, it may be necessary to move up the spacers under the lower bracket to achieve mounting height.

NOTE

If you find that the lower bracket needs to set flat on the leaf spring in order to achieve the correct height and the stock u-bolts are too high to allow this, it will be necessary to trim the stock u-bolts.

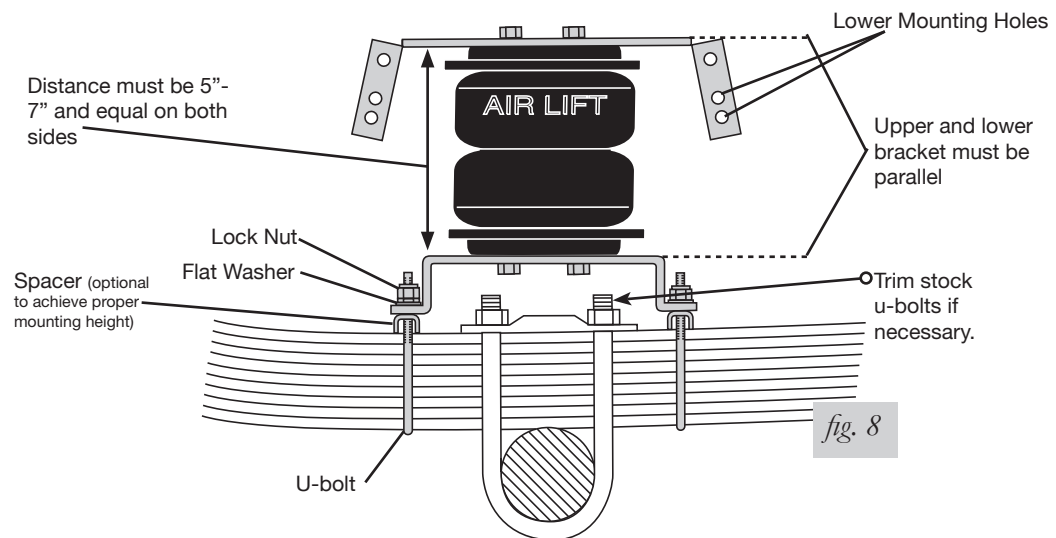

ATTACHING THE LOWER BRACKET

1. If the spacer is not used, attach the lower bracket securely using the provided U-bolts, flat washers, and lock nuts. Torque nuts to 16 lb.-ft. See Figures 1 and 9.

NOTE

Use shorter U-Bolts when attaching to frame contact overload springs.

2. If the spacer is used, place the spacers legs down on the leaf spring and attach the lower bracket securely using the provided U-bolts, flat washers, and lock nuts. Torque nuts to 16 lb.-ft. (Fig. 9).

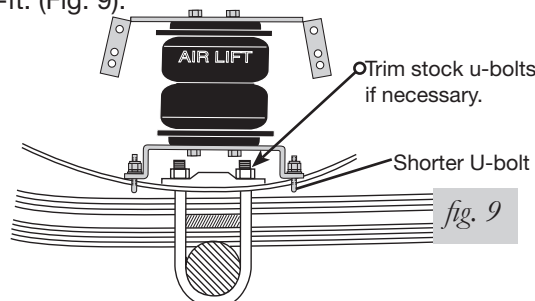

ATTACHING THE UPPER BRACKET

CAUTION

BEFORE DRILLING, CHECK THE BACK-SIDE OF THE FRAME FOR CLEARANCE ISSUES WITH THE BRAKE LINES, GAS LINES, AND ELECTRICAL LINES. ANY OBSTACLES WILL NEED TO BE TEMPORARILY RELOCATED TO CLEAR THE AREA.

1. Position the upper bracket so that it is parallel with the lower bracket and align the assembly vertically and horizontally.
2. Using the upper bracket as a template, center punch and drill one 3/8" locator hole through the frame at one of the top bolt holes (Fig. 10).

NOTE

After achieving the proper alignment, repeat for the opposite side of the bracket.

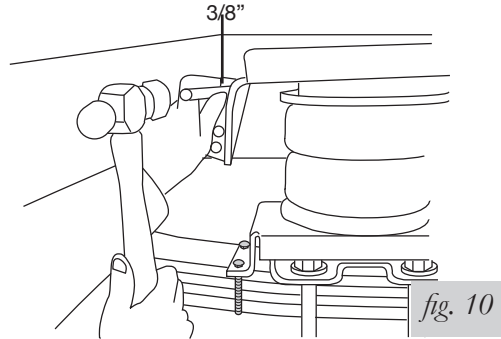

3. Except for Dodge vehicles, loosely install a washer head frame bolt, oversized flat washer, and lock nut (Fig. 11).

For Dodge trucks only: The top two, or the bottom two, holes (depending on the model of the truck) will fall into a horizontal indentation. Spacers are provided to compensate for the indentation. Loosely install a washer head frame bolt, two upper bracket spacers, an oversized flat washer, and a lock nut for such instances (Fig. 12).

4. Install a washer head frame bolt, oversized flat washer, and lock nut.

For Dodge trucks only: It may be necessary to add two of the provided spacers (Fig. 12).

All models, except some late model Dodge trucks

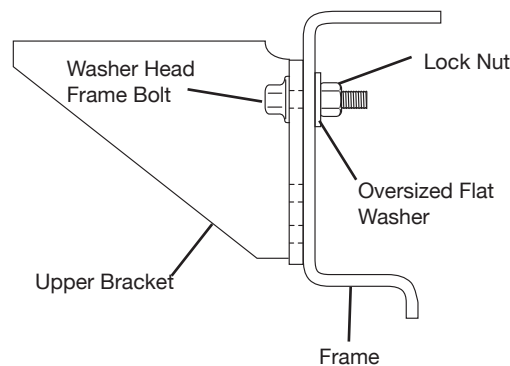

fig. 11

Dodge trucks with ditch

(ditch can be on top or bottom portion of the frame, depending on vehicle model)

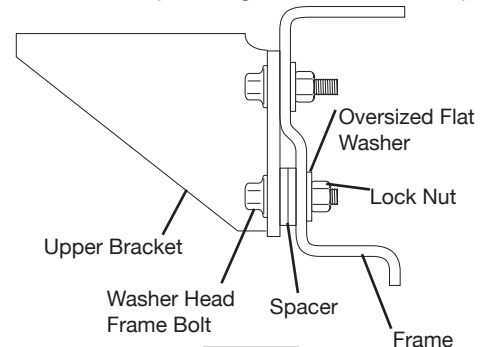
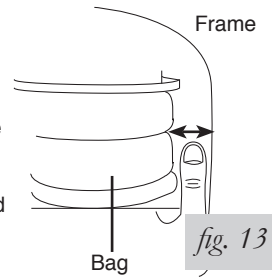

fig. 12

5. Remove the clamps and drill the remaining two holes. Install the appropriate hardware and torque the nuts to 44 lb.-ft.
6. Align the air spring uniformly between the upper and lower brackets and check the air spring alignment (Fig. 13).

Move the air spring in the slots of the upper and lower brackets to align. Make sure there is **at least** a thumbs width of clearance between the uninflated bag and the frame.



SECURING THE AIR SPRING TO THE BRACKETS

1. Secure the air spring to the upper and lower brackets using an open ended 9/16" wrench by tightening the two bolts on the top and the two bolts on the bottom of the spring assembly.

CAUTION

DUE TO THE THICKNESS OF THE LEAF SPRING STACK, TRIM ALL FOUR U-BOLTS ON EACH SIDE OF THE VEHICLE TO PREVENT BOTTOMING OUT ON THE UPPER BRACKET (FIG. 14).

2. Check bolts and connectors to ensure that all hardware is secure and repeat the process for the other side of the vehicle.

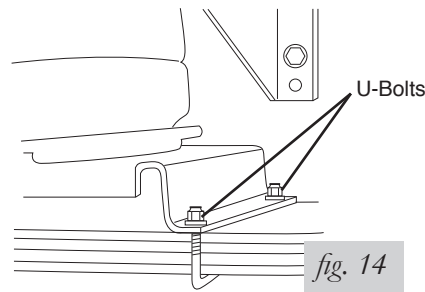

REINSTALLING THE FENDERWELL LINER – LATE MODEL 4WD DODGE ONLY

1. If this installation was on a late model 4WD Dodge truck, it is now necessary to reinstall the inner fenderwell liner using the original fasteners and provided spacers to allow for air spring clearance (Fig. 15).

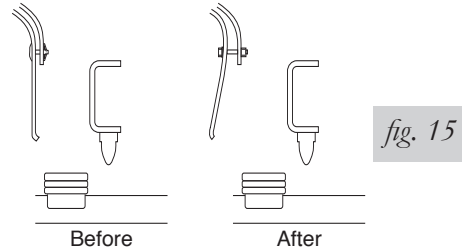

2. Place the spacer between the fenderwell liner and the fenderwell at the center hole in the fenderwell liner (the hole nearest the air spring). Attach using the 1/4" Hex Head Cap Screw (HHCS), the 10/32" flat washers, and 1/4" Nylon lock nut provided (Fig. 16).

NOTE

Fasten the HHCS with the washer and nut behind the fenderwell (Fig. 19). Tighten securely.

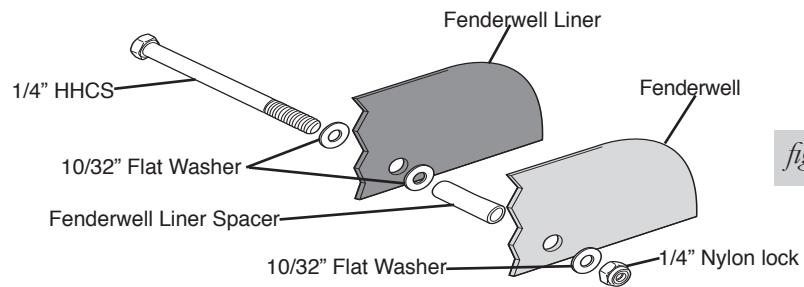

3. Replace the remaining fenderwell liner rivets carefully. Push the rivets through the fenderwell liner by hand. They should push through completely (Fig. 17).
4. From the opposite side, use a rubber mallet and carefully tap the rivet posts back into the rivets in order to secure them properly (Fig. 18). Repeat this process for all remaining rivets.

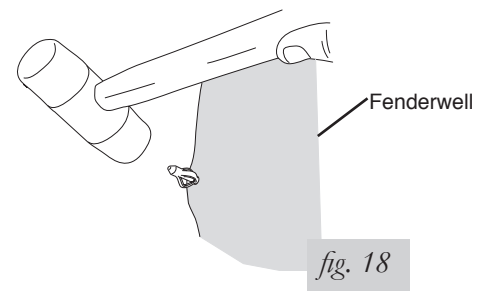
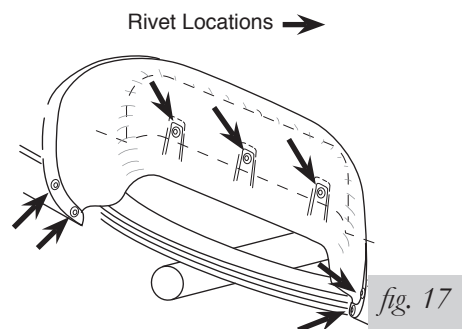

Installing the Air Lines

This section explains how to set up the air spring kit to be controlled with Schrader valves and a separate compressed air source. An on-board air compressor system allows for hassle-free control of the air springs. Learn more about Air Lift control systems at www.airliftcompany.com/products/compressor-systems.

1. Choose a convenient location for mounting the inflation valves (Fig. 19). Popular locations for the inflation valve are:
 - a. The wheel well flanges
 - b. The license plate recess in bumper
 - c. Under the gas cap access door
 - d. Through the license plate

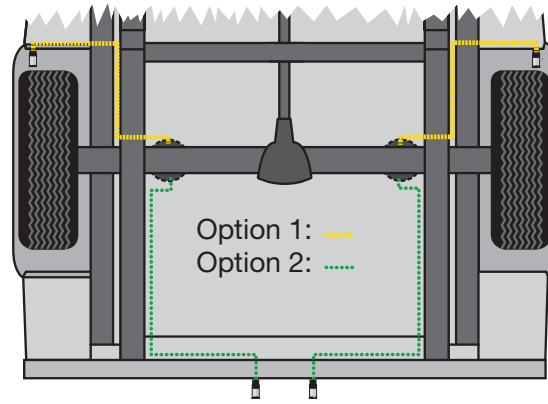
fig. 19
NOTE

Whatever the chosen location, make sure there is enough clearance around the inflation valves for an air chuck.

2. Drill 5/16" holes to install the inflation valves.
3. Cut the air line assembly in two equal lengths.
4. Place a 5/16" nut and star washer on the air valve. Leave enough of the inflation valve in front of the nut to extend through the hole and have room for the rubber washer, flat washer, and 5/16" nut and cap. There should be enough valve exposed after installation –

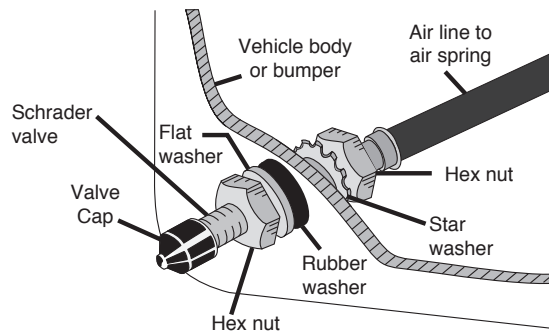
fig. 20

- approximately 1/2" – to easily apply a pressure gauge or an air chuck (Fig. 20).
5. Push the inflation valve through the hole and use the rubber washer, flat washer, and another 5/16" nut to secure it in place. Tighten the nuts to secure the assembly.
6. Route the air line along the frame to the fitting on the air spring. Keep AT LEAST 6" of clearance between the air line and the exhaust system. Avoid sharp bends and edges. Use zip ties to secure the air line to fixed points along the chassis. Be sure that the tie straps are tight, but do not pinch the air line. Leave at least 2" of slack to allow for any movement that might pull on the air line.
7. Cut off the air line, leaving approximately 12" of extra air line. A clean square cut will prevent leaks. Insert the air line into the air fitting. This is a push-to-connect fitting.

TECH TIP

Wiggle the hose back and forth while inserting to make sure the hose bottoms out in the fitting to obtain a good seal.

TIPS FOR INSTALLING AIR LINES

When cutting air lines, use a sharp knife or a hose cutter and make clean, square cuts (Fig. 21). Do not use scissors or wire cutters because these tools may deform the air line, causing it to leak around fittings. Do not cut the lines at an angle.

Do not bend the 1/4" hose at a radius of less than 1" or bend the 3/8" hose at a radius of less than 1 1/2". Do not put side load pressure on fitting. The hose should be straight beyond the fitting for 1" before bending.

Inspect hose for scratches that run lengthwise on hose prior to installation. Contact Air Lift customer service at **(800) 248-0892** if the air line is damaged.



To watch a video demonstrating proper air line cutting, go to air-lift.co/cuttingairline.

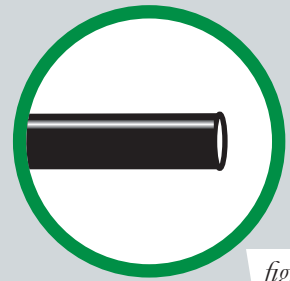

fig. 21



Before Operating

CHECKING FOR LEAKS

1. Inflate the air spring to 30 PSI.
2. Spray all connections and the inflation valves with a solution of 1/5 liquid dish soap and 4/5 water. Spot leaks easily by looking for bubbles in the soapy water.
3. After the test, deflate the springs to the minimum pressure required to restore the system to normal ride height. Do not deflate to lower than 5 PSI.
4. Check the air pressure again after 24 hours. A 2-4 PSI loss after initial installation is normal. Retest for leaks if the loss is more than 5 PSI.

FIXING LEAKS

1. If there is a problem with the swivel fitting:
 - a. Check the air line connection by deflating the spring and removing the line by pulling the collar against the fitting and pulling firmly on the air line. Trim 1" off the end of the air line. Be sure the cut is clean and square (see Fig. 21). Reinsert the air line into the push-to-connect fitting.
 - b. Check the threaded connection by tightening the swivel fitting another half turn. If it still leaks, deflate the air spring, remove the fitting, and re-coat the threads with thread sealant. Reinstall by hand tightening as much as possible and then use a wrench for an additional two turns.
2. If there is a problem with the inflation valve:
 - a. Check the valve core by tightening it with a valve core tool.
 - b. Check the air line by removing the air line from the barbed type fitting. Cut the air line off a few inches in front of the fitting and use a pair of pliers or vice grips to pull/twist the air line off of the fitting.

 **CAUTION**

DO NOT CUT OFF THE AIR LINE COMPLETELY AS THIS WILL USUALLY NICK THE BARB AND RENDER THE FITTING USELESS.

3. If the preceding steps have not resolved the problem, call Air Lift customer service at **(800) 248-0892**.

INSTALLATION CHECKLIST

- Clearance test** — Inflate the air springs to 75-90 PSI and make sure there is at least 1/2" clearance from anything that might rub against each sleeve. Be sure to check the tire, brakes, frame, shock absorbers and brake cables.
- Leak test before road test** — Inflate the air springs to 75-90 PSI and check all connections for leaks. All leaks must be eliminated before the vehicle is road tested.
- Heat test** — Be sure there is sufficient clearance from heat sources, at least 6" for air springs and air lines. If a heat shield was included in the kit, install it. If there is no heat shield, but one is required, call Air Lift customer service at **(800) 248-0892**.
- Fastener test** — Recheck all bolts for proper torque.
- Road test** — The vehicle should be road tested after the preceding tests. Inflate the springs to recommended driving pressures. Drive the vehicle 10 miles and recheck for clearance, loose fasteners and air leaks.
- Operating instructions** — If professionally installed, the installer should review the operating instructions with the owner. Be sure to provide the owner with all of the paperwork that came with the kit.

POST-INSTALLATION CHECKLIST

- Overnight leak down test** — Recheck air pressure after the vehicle has been used for 24 hours. If the pressure has dropped more than 5 PSI, then there is a leak that must be fixed. Either fix the leak yourself or return to the installer for service.
- Air pressure requirements** — It is important to understand the air pressure requirements of the air spring system. Regardless of load, the air pressure should always be adjusted to maintain adequate ride height at all times while driving.
- Thirty-day or 500-mile test** — Recheck the air spring system after 30 days or 500 miles, whichever comes first. If any part shows signs of rubbing or abrasion, the source should be identified and moved, if possible. If it is not possible to relocate the cause of the abrasion, the air spring may need to be remounted. If professionally installed, the installer should be consulted. Check all fasteners for tightness.

Product Use, Maintenance and Servicing

Minimum Recommended Pressure	Maximum Air Pressure
5 PSI	100 PSI

MAINTENANCE GUIDELINES

NOTE

By following the steps below, vehicle owners will obtain the longest life and best results from their air springs.

1. Check air pressure weekly.
2. Always maintain normal ride height. Never inflate beyond 100 PSI.
3. If the system develops an air leak, use a soapy water solution (1/5 liquid dish soap and 4/5 water) to check all air line connections and the inflation valve core before deflating and removing the air spring.

CAUTION

FOR SAFETY AND TO PREVENT POSSIBLE DAMAGE TO THE VEHICLE, DO NOT EXCEED MAXIMUM GROSS VEHICLE WEIGHT RATING (GVWR), AS INDICATED BY THE VEHICLE MANUFACTURER. ALTHOUGH THE AIR SPRINGS ARE RATED AT A MAXIMUM INFLATION PRESSURE OF 100 PSI, THE AIR PRESSURE ACTUALLY NEEDED IS DEPENDENT ON LOAD AND GVWR.

4. Loaded vehicles require at least 25 PSI. A “loaded vehicle” refers to a vehicle with a heavy bed load, a trailer or both. Never exceed GVWR, regardless of air spring, air pressure or other load assist. The springs in this kit will support approximately 40 pounds of load (combined on both springs) for each 1 PSI of pressure. The required air pressure will vary depending on the state of the original suspension. Operating the vehicle below the minimum air spring pressure will void the Air Lift warranty.
5. When increasing load, always adjust air pressure to maintain normal ride height. Increase or decrease pressure from the system as necessary to attain normal ride height for optimal ride and handling. Remember that loads carried behind the axle (including tongue loads) require more leveling force (pressure) than those carried directly over the axle.
6. Always add air to springs in small quantities, checking the pressure frequently.
7. Should it become necessary to raise the vehicle by the frame, make sure the system is at minimum pressure (5 PSI) to reduce the tension on the suspension/ brake components. Use of on-board leveling systems do not require deflation or disconnection.
8. Periodically check the air spring system fasteners for tightness. Also, check the air springs for any signs of rubbing. Realign if necessary.
9. On occasion, give the air springs a hard spray with a garden hose to remove mud, sand, gravel or other debris.

TUNING THE AIR PRESSURE

Pressure determination comes down to three things — level vehicle, ride comfort and stability.

1. Level vehicle

If the vehicle’s headlights are shining into the trees or the vehicle is leaning to one side, then it is not level (Fig. 21). Raise the air pressure to correct either of these problems and level the vehicle.

2. Ride comfort

If the vehicle has a rough or harsh ride it may be due to either too much pressure or not enough (Fig. 22). Try different pressures to determine the best ride comfort.

3. Stability

Stability translates into safety and should be the priority, meaning the driver may need to sacrifice a perfectly level and comfortable ride. Stability issues include roll control, bounce, dive during braking and sponginess (Fig. 23). Tuning out these problems usually requires an increase in pressure.

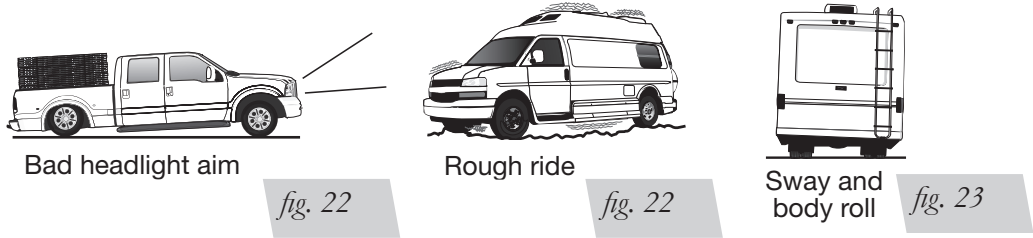

GUIDELINES FOR ADDING AIR

1. Start with the vehicle level or slightly above.
2. When in doubt, always add air.
3. If the front of the vehicle dives while braking, increase the pressure in the front air bags, if equipped.
4. If it is ever suspected that the air bags have bottomed out, increase the pressure (Fig. 24).
5. Adjust the pressure up and down to find the best ride.
6. If the vehicle rocks and rolls, adjust the air pressure to reduce movement.
7. It may be necessary to maintain different pressures on each side of the vehicle.
Loads such as water, fuel, and appliances will cause the vehicle to be heavier on one side (Fig. 25). As much as a 50 PSI difference is not uncommon.

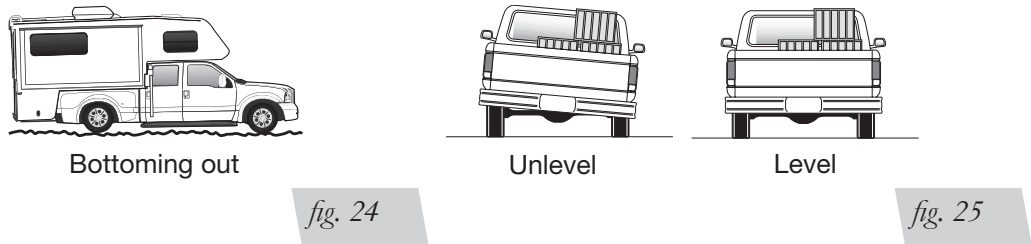

Troubleshooting Guide

PROBLEM	CAUSE	SOLUTION
System won't maintain pressure overnight.	Improperly installed air line, air line has holes or cracks.	Leak test the air line connections, the threaded connection into the air spring, and all fittings in the control system.
Air spring or air line leak.	Fitting seal or air line is compromised.	Check to make sure air lines are seated in connectors. Inspect fittings with soapy water. Trim hose or re-seal fitting. Ensure lines are cut straight.
Corner won't raise or air leak develops.	Look for a kink or fold in the air line.	Replace any air line that has been kinked.

FREQUENTLY ASKED QUESTIONS

Q. Will installing air springs increase the weight ratings of a vehicle?

No. Adding air springs will not change the weight ratings (GAWR, GCWR and/or GVWR) of a vehicle. Exceeding the GVWR is dangerous and voids the Air Lift warranty.

Q. Is it necessary to keep air in the air springs at all times and how much pressure will they need?

For LoadLifter 5000 Ultimate, the recommended minimum air pressure is 5 PSI, but it can safely be run at zero air pressure unladen (no load).

Q. Is it necessary to add a compressor system to the air springs?

No. Air pressure can be adjusted with any type of compressor as long as it can produce sufficient pressure to service the springs. Even a bicycle tire pump can be used, but it's a lot of work.

Q. How long should air springs last?

If the air springs are properly installed and maintained they can last indefinitely.

Q. Will raising the vehicle on a hoist for service work damage the air springs?

No. The vehicle can be lifted on a hoist for short-term service work such as tire rotation or oil changes. However, if the vehicle will be on the hoist for a prolonged period of time, support the axle with jack stands in order to take the tension off of the air springs.



Notes



Notes

Limited Warranty and Return Policy

Air Lift Company provides a limited lifetime warranty to the original purchaser of its Load Support products, that the products will be free from defects in workmanship and materials when used on cars and trucks as specified by Air Lift Company and under normal operating conditions, subject to the requirements and exclusions set forth in the full Limited Warranty and Return Policy that is available online at www.airliftcompany.com/warranty.

For additional warranty information contact Air Lift Company customer service.

Replacement Part Information

If replacement parts are needed, contact the local dealer or call Air Lift customer service at **(800) 248-0892**. Most parts are immediately available and can be shipped the same day.

Contact Air Lift Company customer service at (800) 248-0892 first if:

- Parts are missing from the kit.
- Need technical assistance on installation or operation.
- Broken or defective parts in the kit.
- Wrong parts in the kit.
- Have a warranty claim or question.

Contact the retailer where the kit was purchased:

- If it is necessary to return or exchange the kit for any reason.
- If there is a problem with shipping if shipped from the retailer.
- If there is a problem with the price.

Contact Information

Mailing address	P.O. Box 80167 Lansing, MI 48908-0167
Shipping address for returns	2727 Snow Road Lansing, MI 48917
Phone	Toll free: (800) 248-0892 International: (517) 322-2144
Email	service@airliftcompany.com
Web address	www.airliftcompany.com

Need Help?

Contact Air Lift Company customer service department by calling (800) 248-0892.

For calls from outside the USA or Canada, dial (517) 322-2144.



Thank you for purchasing Air Lift products — the professional installer's choice!

Air Lift Company • 2727 Snow Road • Lansing, MI 48917 or P.O. Box 80167 • Lansing, MI 48908-0167
Toll Free (800) 248-0892 • Local (517) 322-2144 • Fax (517) 322-0240 • www.airliftcompany.com

Printed in the USA
JJC-0117