



TRAXDA
Lift Kits - Made in USA

Toll free: 888-660-5892
email: info@traxda.com

SAFETY WARNING!
Always use the correct tools, and wear safety goggles. We **STRONGLY** recommend installation by a licensed mechanic on a properly secured locking lift.

Traxda LLC, 810 E 19th Street
Tucson, Arizona 85719

TIRE FITMENT ADVICE

The best way to ensure proper tire fitment is to install the kit before purchasing your wheels and tires. Always test fit tires and wheels before purchasing.

VEHICLE RIDE WARNING!

Trucks with lift or level kits installed have a higher center of gravity. Aggressive and sudden direction changes may cause a tip over.

403080 GMC Canyon, Chevrolet Colorado
Lift and Level Kit

This kit contains:
2 - Spring Preload Spacers
2 - Upper Strut Spacers
Instructions
Warranty Card
Stickers



Installation Tips

Always use caution handling ABS or wheel sensor wiring. Avoid tension of any kind on wiring harness as this may cause damage or failure.

1. Trucks are often not level side to side from the factory. Please measure before installation.
2. Re-torque all hardware to manufactures specifications
3. When aligning, to get the best tire wear use our supplied specifications. OEM specifications are for trucks with stock wheels and tires. Larger tires will wear differently.
4. All instructions are written with vehicle on a 2-post lift with tires removed.

Step 1

Loosen and remove the upper ball joint nut, tie rod nut, and sway bar nut. A hammer may be needed to break the ball joint and tie rod free.

Special Note:

On 4x4 models you must remove the drive axle nut. **Failure to follow this step will make removal of the strut difficult.**

Step 2

Remove the strut from the vehicle and **mark the strut for proper re-assembly**. Using a spring compressor tool, disassemble the strut and install the TRAXDA part.

*Refer to Figure A for proper placement.

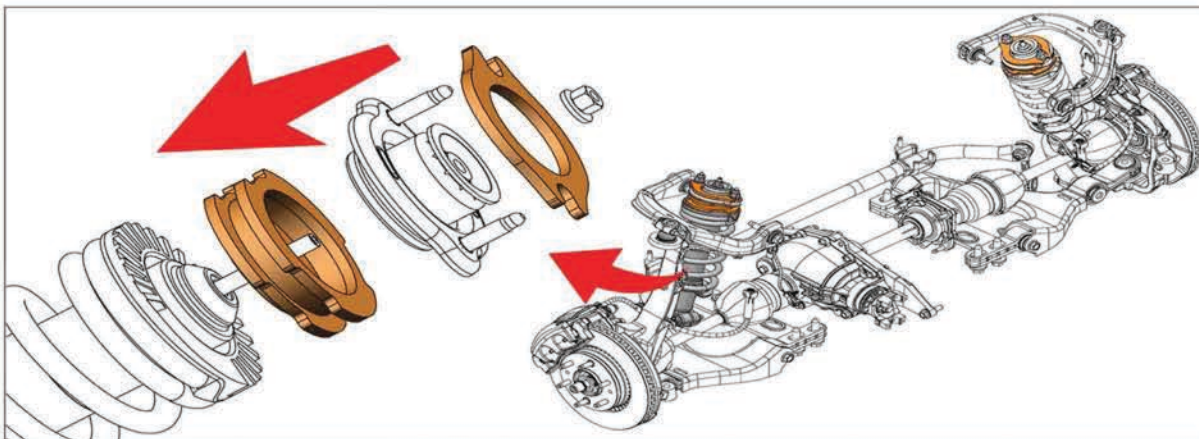

Figure A

Illustration is for reference only. Part dimensions will vary from kit to kit.

Installation Instructions continued on reverse



TRAXDA
Lift Kits - Made in USA

Toll free: 888-660-5892
email: info@traxda.com

SAFETY WARNING!
Always use the correct tools, and wear safety goggles. We **STRONGLY** recommend installation by a licensed mechanic on a properly secured locking lift.

Traxda LLC, 810 E 19th Street
Tucson, Arizona 85719

TIRE FITMENT ADVICE
The best way to ensure proper tire fitment is to install the kit before purchasing your wheels and tires. Always test fit tires and wheels before purchasing.

VEHICLE RIDE WARNING!
Trucks with lift or level kits installed have a higher center of gravity. Aggressive and sudden direction changes may cause a tip over.

403080 Installation Instructions continued

Step 3

Reinstall the strut assembly in its stock location. Then reinstall the upper ball joint nut followed by the tie rod nut and sway bar nut.

*It may be necessary to use a pry bar to aid in the re-installation of the strut assembly, and a pit jack to raise the lower control arm to get the upper ball joint nut installed.

Verify that all hardware has been tightened to the proper torque specs and re-install wheel.

Step 4

Repeat steps 1 through 3 on the opposite side of the vehicle.

Step 5

Wheel alignment specifications

Alignment notes:

We recommend that a technician with experience doing alignments on lifted trucks perform the alignment. Large tires wear differently than OEM sized tires. Always do an alignment after changing tires on a vehicle.

	Left	Right
Caster (degrees)	3.5	4
Camber (degrees)	0	-1/4 or -.25
Toe	1/16 or .0625 inch toe in	
Special Tools	none	

WARNING! This TRUXXX leveling kit is designed and engineered to level out a stock vehicle with no prior modifications. The use of this kit along with items such as a rear add a leaf, airbags, suspension lifts, body lifts or any other type of lifting accessory, **shall be done at the vehicle owners risk.**